



APL Anchor Plates

Instructions for installation and use

PFEIFER

Instructions for installation and use

Storage

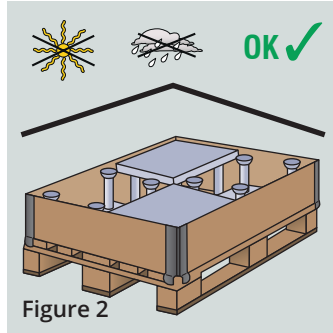
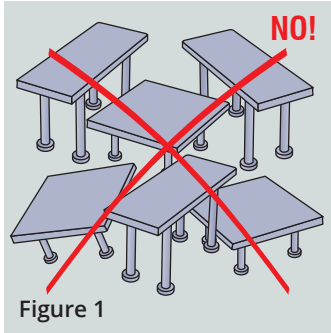

Installation – formwork fixing

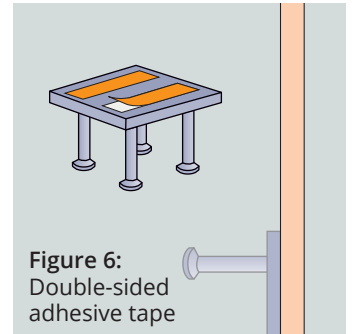
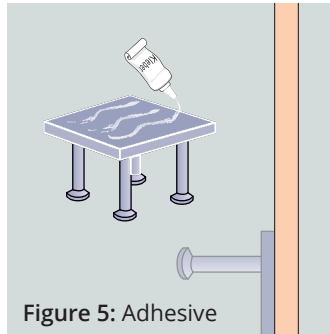
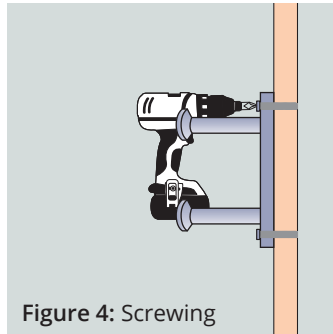
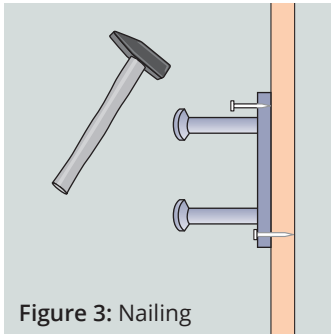

Notices:

The PFEIFER APL anchor plates can simply be nailed or screwed to the formwork through holes in their steel plate (Figs. 3 and 4). Alternatively, the product can also be glued to the formwork on the smooth steel plate (Figs. 5 and 6). It should be checked whether the selected adhesive has a sufficiently high adhesive force. In general, it is recommended to additionally bind the anchor plates to the reinforcement (Fig. 10).

This prevents sinking and slipping and also stabilises the fixing to the formwork.

Installation – tolerances and notes

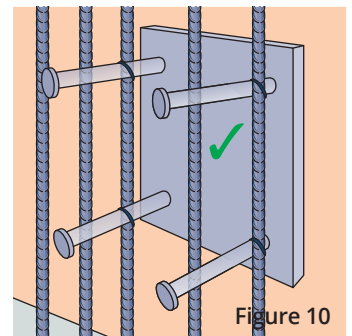
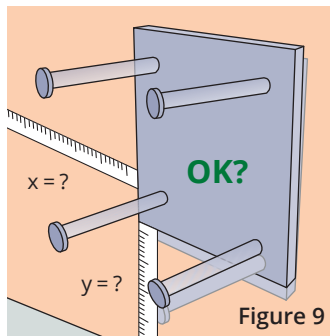
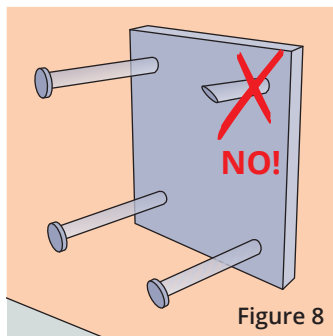
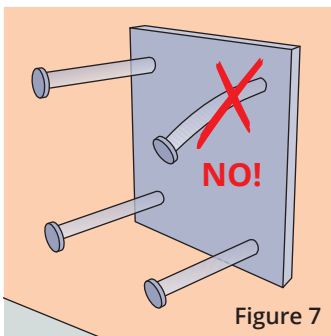

Instructions for installation and use

Intended use

Anchor plates are used to fasten steel components to concrete elements. To this end the anchor plates are cast in the concrete element. The headed studs serve as anchorage. During the installation state the steel plate is flush with the surface of the concrete. A steel component can be welded to this side.

Figs. 11 to 14 show examples of possible applications:

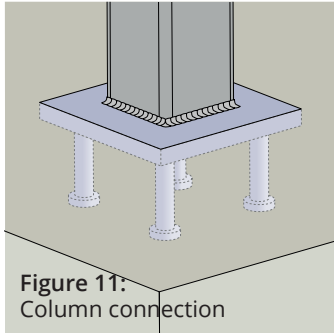

Figure 11:
Column connection

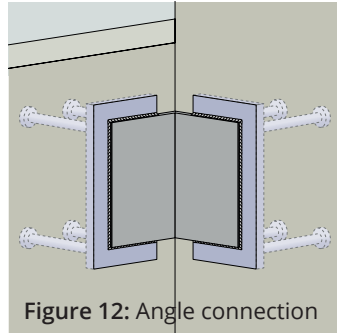

Figure 12: Angle connection

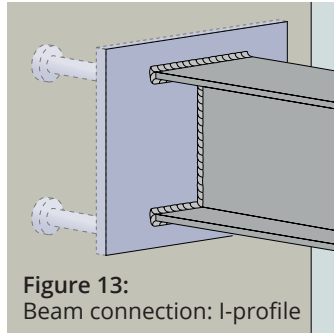

Figure 13:
Beam connection: I-profile

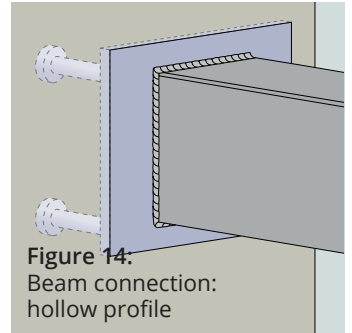

Figure 14:
Beam connection:
hollow profile

Hints during the usage

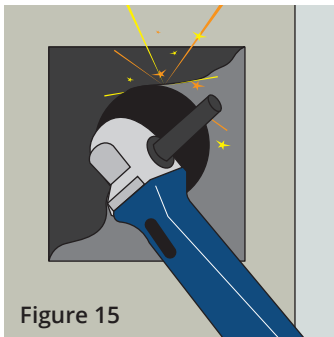

Figure 15

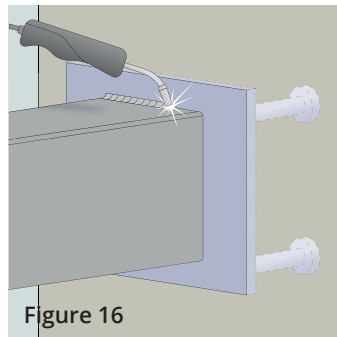

Figure 16

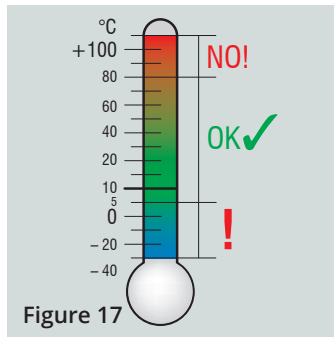

Figure 17



Notices:

- The steel parts must be dried and freed from snow, ice, rust and other contaminants prior to welding.
- Existing paint or galvanizing in the welding area has to be removed. (Fig. 15).
- Steel components have to be welded by qualified personnel in compliance with the applicable rules for welding on structural steelwork.
- Ground and welded areas have to be protected against corrosion by the user according to his requirements, for example by cold zinc plating or coating with paint.



Notices:

- It is recommended to pre-heat the parts to be welded if the ambient temperature is below + 5 °C.
- With solid components in particular the pre-heating (< +80 °C) is important in order to avoid the risk of brittle failure.
- Do not overheat, this may damage the concrete.

DEUTSCHLAND

87700 Memmingen
+49 (0) 83 31937345
bautechnik@pfeifer.de

ÖSTERREICH

+49 (0) 160 2875039
export@pfeifer.de

SCHWEIZ

8934 Knonau
+41 (0) 447 68 5555
info@pfeifer-isofer.ch

www.pfeifer.info/bautechnik

PFEIFER