



# Power Plants

JORDAHL® Anchor Channels JXA-PC



**JORDAHL®**  
anchored in quality

# JORDAHL® Anchor Channels

## Features

- Quick, efficient anchoring on site
- Simple assembly
- Anchoring without damage to the concrete or reinforcement
- Suitable without restriction for cracked or uncracked concrete
- Reduced construction time
- Approved for use within structural elements subject to fire prevention requirements
- European Technical Approval (ETA-09/0338) and German Technical Approval (Z-21.4-151) issued by the German Institute for Structural Engineering (DIBT)
- Increased load bearing capacity near reinforcement
- Long-lasting, maintenance-free through the use of corrosion-resistant grades of stainless steel
- Suitable for pre-stressed and post-tensioned structures



### Toothed W Profiles PC – Power Connection Channel

- Approved for dynamic, shock and fatigue loads
- Suitable for safety relevant areas
- 3D load capacity in all directions
- High resistance under seismic impact
- Fire protection for up to 90 minutes
- Increased load capacity due to special anchor geometry

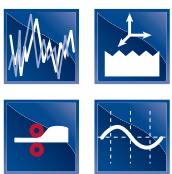

### Toothed W Profiles

- Universal load capacity also in the longitudinal direction of the channel
- Toothed profiles have German Technical Approval (W profiles: Z-21.4-1690)
- 3D load capacity in all directions

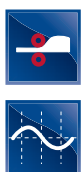

### W Profiles

- Hot rolled from a single block
- Free from internal stresses
- Optimized geometry with strengthened channel lips for high tightening torques
- Suitable for dynamic loads
- Resistant to fatigue up to the working load limit



### JORDAHL® Bolts

- Hammer-head and T-head bolts – matched to JORDAHL® profiles
- Galvanized or from stainless steel
- Strong connections using high bolt tightening torques



work safety



reduces construction time



economical



simple assembly



fire prevention



sustainable construction

# Content

<b>JORDAHL® Anchor Channels</b>	
Features	2
<b>Requirements for Safety Critical Connections</b>	
Regular Loads	4
Seismic Loads	4
Power Plants	4
<b>Qualification of Anchor Channel for Safety Relevant Applications</b>	<b>5</b>
<b>Applications in Power Plants</b>	<b>6</b>
<b>Product Overview</b>	
Anchor Channels JXA-PC	7
Bolts JX	8
<b>Technical Data</b>	
Design Loads	9
Minimum Distances	9
<b>Features and Benefits</b>	
JXA-Power Channel	10–11
<b>Product Overview Anchor Channels</b>	
JXA-PC W – for Power Plants	12
JXA W – for Seismic Loads	13
JTA W – for Regular Dynamic Loads	14
JTA K – for Regular Static Loads	15

All rights reserved.  
The right to make changes within the course of product-  
and application-related further developments is reserved.

JORDAHL GmbH  
Nobelstrasse 51  
12057 Berlin, Germany  
[www.jordahl.de](http://www.jordahl.de)

# Requirements

## for Safety Critical Connections

### Regular Loads

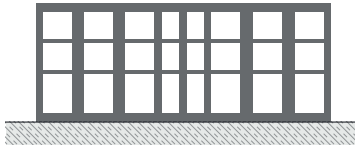

Standard concrete structures under regular load combinations do not need special consideration to resist seismic lateral loads or cracks in the structure. The crack width is controlled by the amount of reinforcement and is limited to a maximum of 0.3 mm (EC 1992-1). For connections where loading is only considered in two directions (tension and shear) the JTA W and JTA K anchor channels are most efficient.

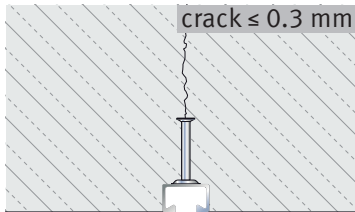

Anchor Channel JTA W

### Seismic Loads

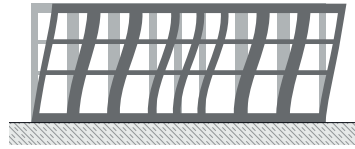

Connections with loads in all three directions, or designed to resist seismic impacts, need anchor channels with lateral bearing capacities. Most suitable for these applications are hot rolled toothed JXA W channels. Under seismic loads the structure of a building may deform and cracks of up to 0.5 mm are likely to occur. The suitability of anchor channels JXA W under such seismic loads has been verified by simulated seismic tests according ACI 355 and 349-06. These tests were carried out in concrete with crack openings of 0.5 mm. Due to the shape of the anchor head and the stiff channel body, JORDAHL® channels provide excellent performance and are the recommended solution for this category of connections.

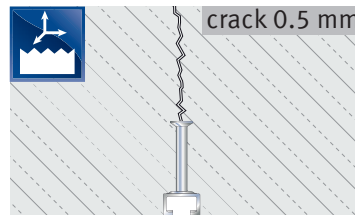

Anchor Channel JXA W

### Power Plants

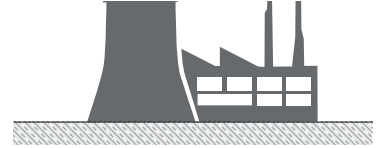

Safety relevant structures in nuclear power plants or structures in other hazardous areas, where functionality is of vital importance, require special consideration to resist extraordinary impacts. Impacts as for example explosions or plane crashes may cause serious deformation to the concrete structure, which makes the use of special anchors necessary. The suitability of the anchor channel JXA-PC has been verified by simulated seismic and shock tests with concrete cracks openings of 1.5 mm. The large anchor head and the toothed lips of the JXA-PC allow a very safe and reliable anchorage even under extreme impacts.

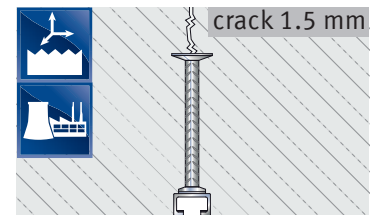

Anchor Channel JXA-PC W

# Qualification

## of Anchor Channels for Safety Relevant Applications

Anchors in concrete for nuclear power plants have to be tested to resist cycling load impacts in combination with certain crack widths. Anchors can qualify for three different categories A1 to A3 in accordance with DIN 25449.

The strictest category A3 is defining loads that occur only once during the lifetime circle of the facility. These loads include hazardous impacts from inside and outside such as:

- Earthquake
- Flood
- Plane crash
- Explosion
- Fire

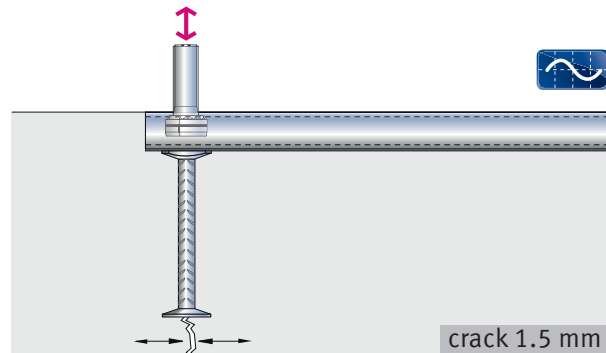

In addition, the requirement for the test setup is to install the anchors in a crack of 1.5 mm. After specific load cycles a final pull-out test is performed to assess the remaining capacity of the anchor channels.

### Load Displacement Curve of JXA-PC Tension Test

The load displacement curve shows in Figure 1 a typical behaviour of the JORDAHL® JXA-PC channel in a dynamic tension test in cracked concrete. Anchor channels are installed in concrete specimen that allow opening cracks at the specific location of the anchor. In the test, after opening the crack to 1.5 mm, the anchor channel is loaded with 15 load cycles① of 1.8 times the maximum allowable load. The final failure② after the cycling still shows a high remaining capacity and very ductile behaviour. This is needed to ensure redistribution of the load and reliable performance of the structure under shock impacts.

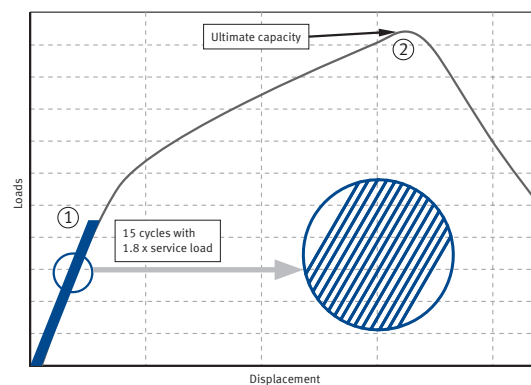
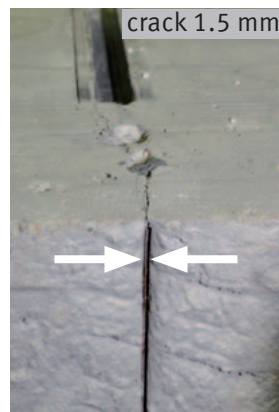

Figure 1

### Performed Test in Cracked Concrete



Test setup for cyclic pull out tests



Open crack



Test setup for cyclic shear test

# Applications in Power Plants



Power plant under construction



Anchor channels in elevator shaft or stairway



Fastening of exterior ladder



Fastening of ventilation/ aeration pipes



Fastening of cable trays



Fastening of heavy machinery



Fastening of heavy duty water pipes



# Product overview

## Anchor Channels JXA-PC

JXA-PC W 64/44-FV/HDG		Available lengths	
		Length [mm]	Anchors [Pieces]
		200	2
		350	3
		400	3
		550	3
		800	4
		1050	5
		6000	25

JXA-PC W 53/34-FV/HDG		Available lengths	
		Length [mm]	Anchors [Pieces]
		200	2
		350	3
		400	3
		550	3
		800	4
		1050	5
		6000	25

JXA-PC W 38/23-FV/HDG		Available lengths	
		Length [mm]	Anchors [Pieces]
		200	2
		350	3
		400	3
		550	3
		800	4
		1050	5
		6000	25

JXA-PC W 29/20-FV/HDG		Available lengths	
		Length [mm]	Anchors [Pieces]
		200	2
		350	3
		550	4
		800	5
		1050	6
		3000	16
		6000	31

### Material and Design of Profile

- Hot-dip galvanized steel (HDG)
- Stainless steel on request (A4)
- Standard filler polyethylene (PE) or polystyrene (PS)

Other lengths are available on request.

# Product overview

## Bolts JX

Toothed Bolts	Type JXE	Type JXB	Type JXH	Type JXD				
for Profile	JXA-PC W 64/44	JXA-PC W 53/34	JXA-PC W 38/23	JXA-PC W 29/20				
Bolt Length L [mm]	JXE M 20	JXE M 24	JXB M 16	JXB M 20	JXH M 12	JXH M 16	JXD M 10	JXD M 12
30					hdg 8.8	hdg 8.8		hdg 8.8
40					hdg 8.8 F4-70	hdg 8.8	hdg 8.8	hdg 8.8 F4-70
50					hdg 8.8	hdg 8.8		hdg 8.8
60			hdg 8.8 F4-70		hdg 8.8 F4-70	hdg 8.8 F4-70		hdg 8.8 F4-70
80			hdg 8.8 F4-70	hdg 8.8 F4-70	hdg 8.8	hdg 8.8		
100	hdg 8.8 F4-70	hdg 8.8 F4-70	hdg 8.8 F4-70	hdg 8.8 F4-70	hdg 8.8	hdg 8.8		hdg 8.8
125						hdg 8.8		hdg 8.8
150				hdg 8.8 F4-70		hdg 8.8		hdg 8.8

Other lengths are available on request.

### Design Resistance, Bending Moments and Tightening Torque

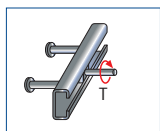
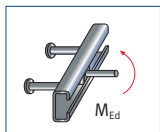
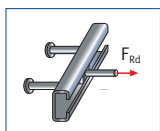

Profile	Bolts Ø	M 10	M 12	M 16	M 20	M 24
		JXA-PC	W 29/20	Toothed bolt JXD		–
		W 38/23	Toothed bolt JXH		–	–
		W 53/34	–	Toothed bolt JXB		–
		W 64/44	–	–	Toothed bolt JXE	
Design Resistance $F_{Rd}$ [kN]	HDG 8.8	18.6	27.2	50.5	79.0	113.7
	A4-70	12.2	17.6	33.0	51.5	95.1
Bending Moments $M_{Rd}$ [Nm]	HDG 8.8	34.9	61.2	155.4	303.0	718.3
	A4-70	26.2	45.9	116.6	227.2	503.2
Through-Hole in Anchor Element [mm]		12	14	18	22	26
Tightening Torque T [NM]	JXA	W 29/20	40	80	–	–
		W 38/23	–	80	120	–
		W 53/34	–	–	200	350
		W 64/44	–	–	–	350

### Ordering Example of Anchor Channels JXA-PC

Type	Profile	Channel Length [mm]	Material
JXA-PC	W 38/23	3000	HDG

### Ordering Example of Bolts

Type	Thread Ø	Length [mm]	Material
JXH	M16	× 100	HDG

### Tender Specification

1. JORDAHL® power channels  
 JORDAHL® anchor channel JXA-PC with ribbed steel anchors, hot-dip galvanized (FV/HDG) with Polystyrene filler (PS), for static and fatigue loads in all directions, for earthquake resistant and adjustable fastening of constructions in safety relevant buildings/power stations.

2. JORDAHL® Bolts JX  
 JORDAHL® toothed bolts matched to JXA-PC profiles, galvanized or from stainless steel.



# Technical Data

## Design Loads for JXA-PC Anchor Channels

for Concrete Classes  $\geq C 20/25$  <sup>1)</sup>

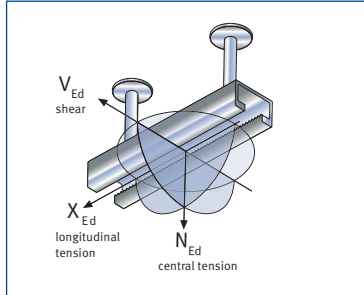

$$\sqrt{N_{Ed}^2 + V_{Ed}^2 + X_{Ed}^2} \leq F_{Rd}$$

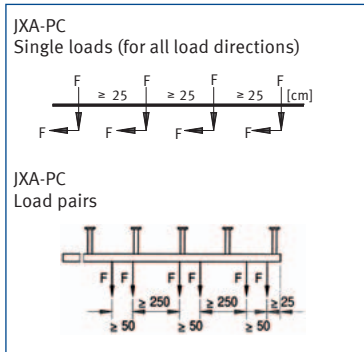

Profile JXA-PC	Corresponding Bolt	Design Load $F_{Rd}$ [kN] <sup>2) 3)</sup> Stressing in All Directions		
		Toothed Bolts		Load Pairs
		Profile Length [mm]	Single Load	$\geq 200$
		Load Distance [mm]	$\geq 250$	$\geq 150$
<b>W 29/20</b>	JXD M 10	11.2	6.3 <sup>4)</sup>	9.0 <sup>4)</sup>
	JXD M 12			
<b>W 38/23</b>	JXH M 12	16.8	9.4 <sup>4)</sup>	12.0 <sup>4)</sup>
	JXH M 16			
<b>W 53/34</b>	JXB M 16	30.8 (26.6) <sup>5)</sup>	–	19.25 <sup>6)</sup>
	JXB M 20			
<b>W 64/44</b>	JXE M 20	37.8	–	23.7
	JXE M 24			

- <sup>1)</sup> When anchoring in concrete with strength grade C 12/15, the permissible loads for C 20/25 must be reduced by a factor of 0.7 and for light-weight concrete with closed structure  $\geq LC 25/28$  by a factor of 2/3.
- <sup>2)</sup> See below for the minimum edge distance.
- <sup>3)</sup> In the event of simultaneous stressing in different directions the resultant load must not exceed the design load  $F_{Rd}$ .
- <sup>4)</sup> Intermediate values may be interpolated.
- <sup>5)</sup> Only applies to channels made of A4.
- <sup>6)</sup> The minimum distance for profiles W 53/34 and 64/44 is 100 mm.

## Minimum Distances and Minimum Dimensions for all Concrete Strength Grades <sup>7)</sup>

Profile JXA-PC	$a_r$	$a_a$	$a_e$	$a_f$	$b$ <sup>8)</sup>	$d$ <sup>9)</sup>	Channel Pair <sup>10)</sup>	
							$a_{r1}$	$a_{a1}$
<b>W 29/20</b>	100	200	80	200	200	$165 + c_{nom}$	140	125
<b>W 38/23</b>	150	300	130	250	300	$170 + c_{nom}$	225	150
<b>W 53/34</b>	200	400	175	350	400	$180 + c_{nom}$	–	–
<b>W 64/44</b>	250	500	225	450	500	$200 + c_{nom}$	–	–

<sup>7)</sup> The minimum spacings given in the table are valid for reinforced concrete. Edge distance and geometry limitations are subject to national building regulations. They might vary with the loading. Please ask for consultation and individual proposal.

<sup>8)</sup> Applies to the use of one channel

<sup>9)</sup> Is derived from the installation height of the anchor channel and the required concrete cover  $c_{nom}$ .

<sup>10)</sup> Only permissible for tension

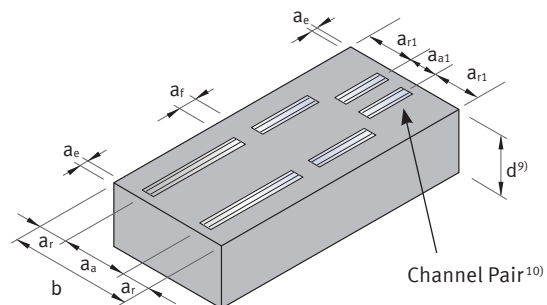

# Features and Benefits

## JXA-Power Channel

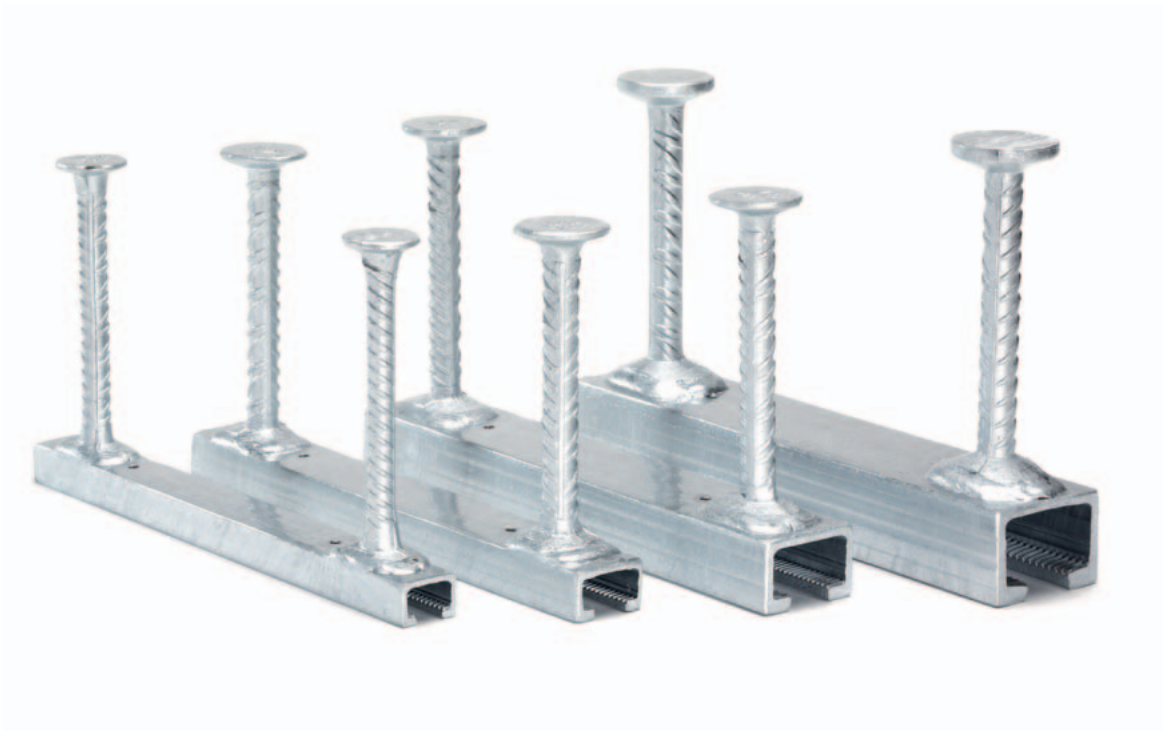

### Big Undercut Anchor Head

- Assures reliable interlock even in large cracks
- Allows transfer of high forces with low bearing pressures
- Minimizes displacements of embed
- Hot forged very suitable for fatigue resistance (no residual stress)

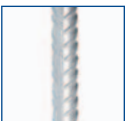
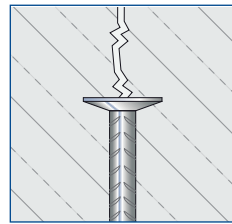

### Longer Anchor Shaft with ribbed surface

- Additional anchorage depth transfers loads deeper into structure
- Ribbed surface allows bonding between anchor and concrete
- Compensates concrete spalling under fire
- Penetrates multiple layers of reinforcement in highly reinforced sections

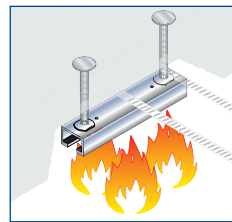

### JXA W Profile

- Hot rolled steel profile with optimized geometry
- Ductile behaviour of channel for energy absorption (see Figure 1)
- Approved for high installation torques (no additional locking of nuts needed)
- Tested and approved for fatigue loads for up to 2 million load changes
- Available in hot dip galvanized or stainless steel

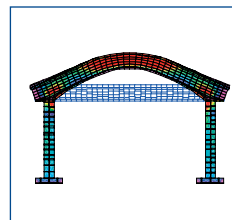
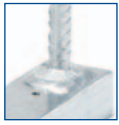
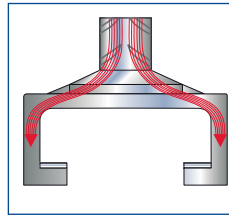

Figure 1



#### Anchor Foot

- Circular weld allowing even load flow between anchor and channel
- Reduced notching stress in the weld, due to large weld area



#### Toothed Channel Lips

- Interlocking with matching T-bolt
- Allowing high bearing strength in lateral direction of the channel
- Suitable for seismic loads and impacts from explosions etc.

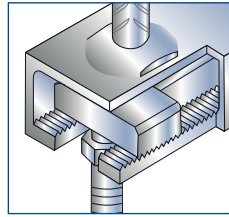

#### Toothed Bolts

- Approved for high torque moments
- Solid interlock with toothed channel
- Available in high strength class 8.8 and stainless steel

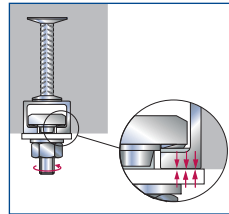

#### Certified Quality

Monitored quality by internal and 3<sup>rd</sup> part quality control

- Certified by DIBt and EOTA
- Certified with CE mark of conformity
- Certified QM/QC program in accordance with ISO 9001
- Material specification certificates class 2.1, 2.2 and 3.1 are available

Full tracing of products from mill to job site is available



#### Service

##### Worldwide Technical Advice

In addition to the technical information in our brochures and on our website, our engineers will make static calculations and provide technical advice on request.

- **Design Software**
- **Tender Texts**
- **Installation Instructions**

Further Information on [www.jordahl.de](http://www.jordahl.de)

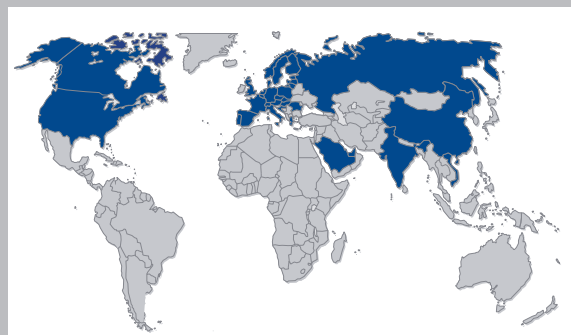

# Anchor Channels JXA-PC

Seismic, dynamic and static performance  
in all directions in **large** crack

Hot Rolled Toothed Anchor Channels for Power Plants  
with Ribbed Anchors and Large Heads



## JXA-PC W 64/44

$$N_{Rd} = V_{Rd} = X_{Rd} = 37.8 \text{ kN}$$

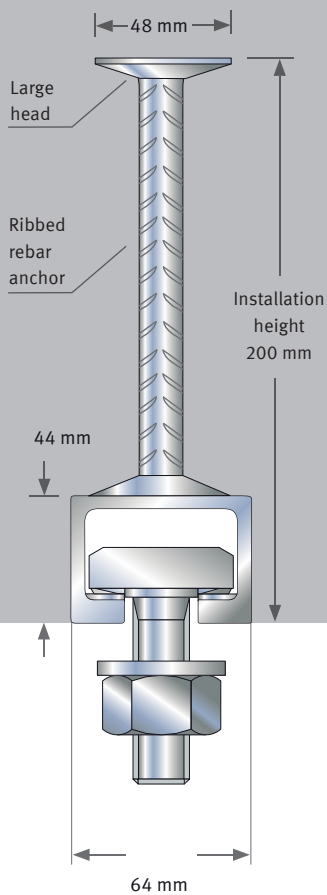

## JXA-PC W 53/34

$$N_{Rd} = V_{Rd} = X_{Rd} = 30.8 \text{ (26.6)}^1 \text{ kN}$$

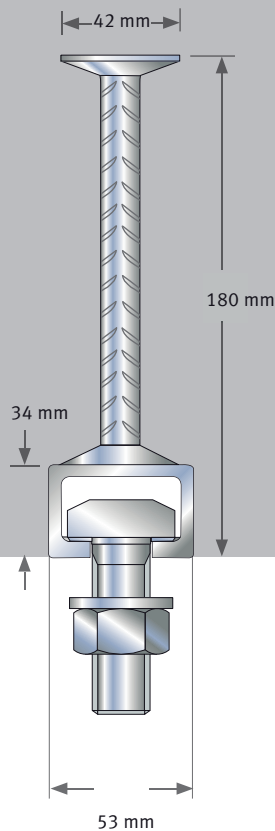

## JXA-PC W 38/23

$$N_{Rd} = V_{Rd} = X_{Rd} = 16.8 \text{ kN}$$

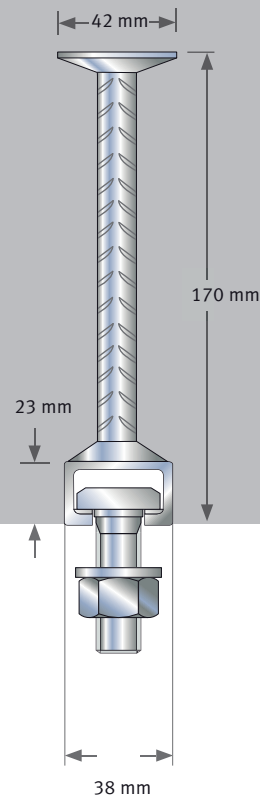

## JXA-PC W 29/20<sup>2)</sup>

$$N_{Rd} = V_{Rd} = X_{Rd} = 11.2 \text{ kN}$$

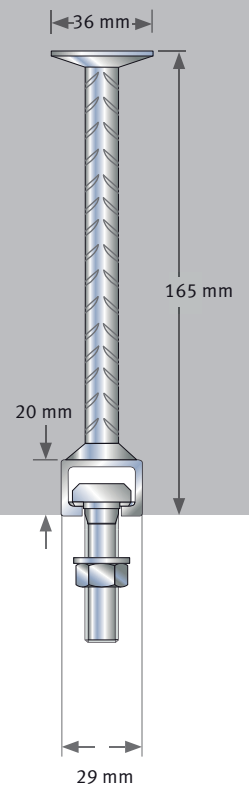

## Toothed Bolts

JXE	JXB	JXH	JXD
M 20	M 16	M 12	M 10
M 24	M 20	M 16	M 12

<sup>1)</sup> For profiles made in A4 = 26.6 kN

<sup>2)</sup> Only in hot-dipped galvanized (HDG)  
Profile dimensions may exhibit tolerances.

### Material and Design of Profile

- Hot-dip galvanized steel (HDG)
- Stainless steel on request (A4)
- Standard filler polyethylene (PE) or polystyrene (PS)

### Material and Design of Bolts

- Zinc plated (ZP) or hot-dip galvanized steel (HDG)
- Stainless steel

# Anchor Channels JXA

Seismic, dynamic and static performance  
 in all directions in **small crack**

Hot Rolled Toothed Anchor Channels for Seismic Loads with Round Anchors and Normal Heads

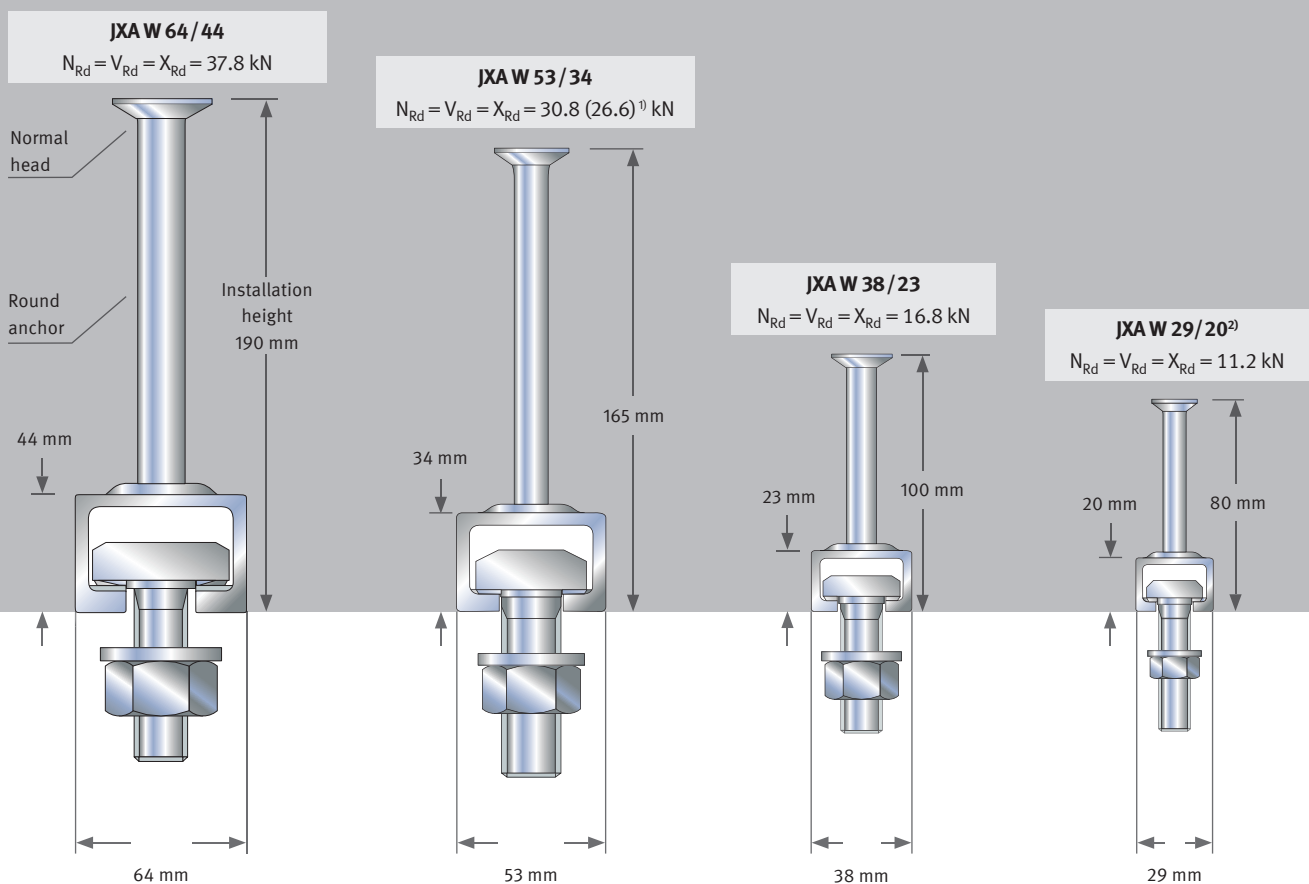

## Toothed Bolts

JXE	JXB	JXH	JXD
M 20	M 16	M 12	M 10
M 24	M 20	M 16	M 12

$N_{Rd}$  = Design value for axial force  
 $V_{Rd}$  = Design value for shear force  
 $X_{Rd}$  = Design value for longitudinal force

Anchor channels are available in lengths from 100 to 6.050 mm.

# Anchor Channels JTA-CE

Dynamic and static performance in small cracks  
European Technical Approval ETA-09/0338

Hot Rolled Anchor Channel for Regular Dynamic and Static Loads

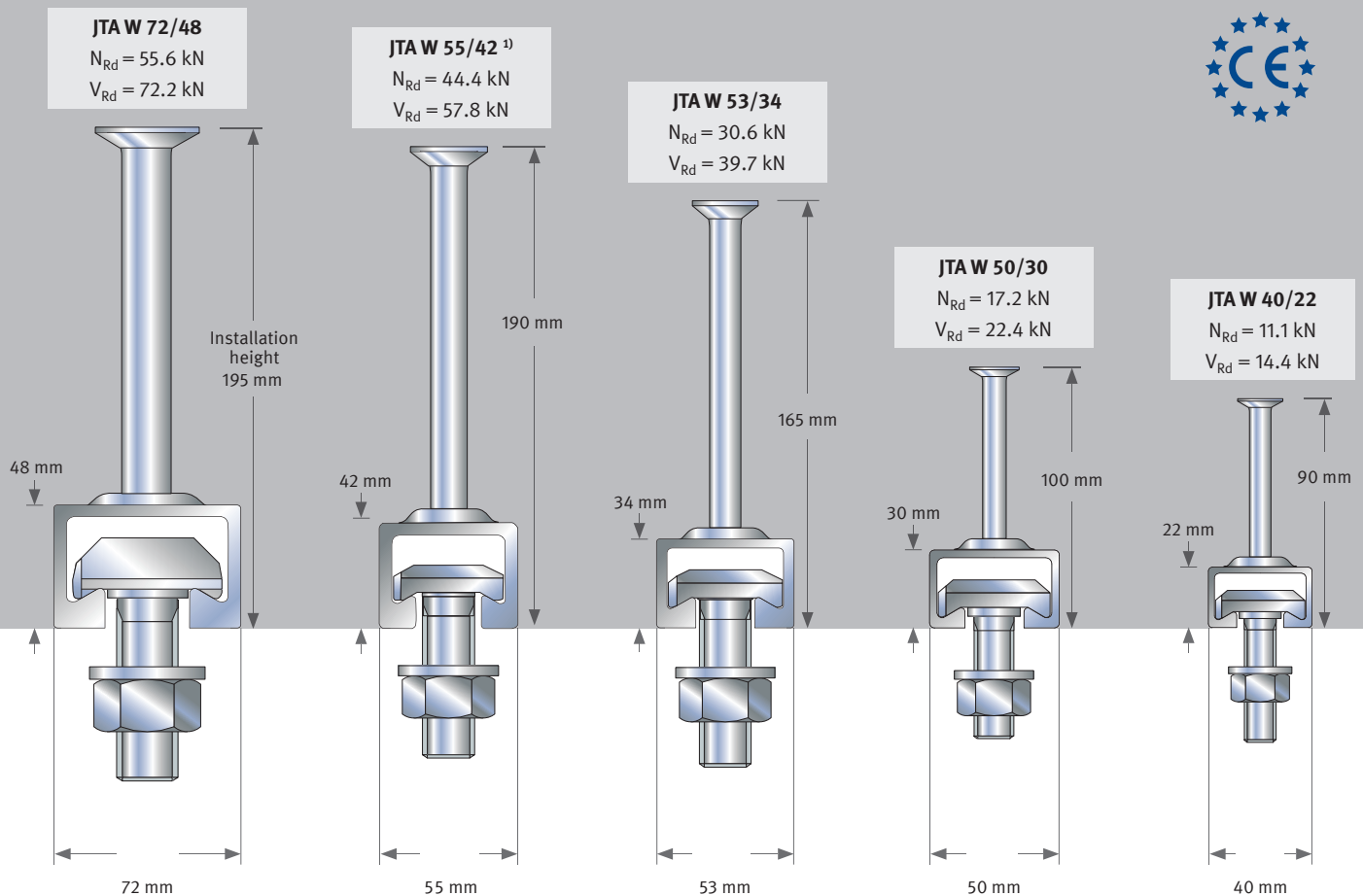

## Bolts

JA	JB	JB	JB	JC
M 20	M 16	M 10	M 10	M 10
M 24	M 20	M 12	M 12	M 12
M 27	M 24 <sup>2)</sup>	M 16	M 16	M 16
M 30		M 20	M 20	

<sup>1)</sup> Only in hot-dip galvanized (HDG)  
<sup>2)</sup> JB M 24 is equivalent to JE M 24  
<sup>3)</sup> Cold formed toothed anchor channel  
 (German Technical Approval Z-21.4-741)  
 Profile dimensions may exhibit tolerances.  
 Round anchor = standard version;  
 I-anchor = delivery subject to confirmation

**Material and Design of Profile**

- Hot-dip galvanized steel (HDG)
- Stainless steel (A4)
- Standard filler polyethylene (PE) or polystyrene (PS)

**Material and Design of Bolts**

- Zinc plated (ZP) or hot-dip galvanized steel (HDG)
- Stainless steel

# Anchor Channels JTA-CE

Static performance in small cracks

European Technical Approval ETA-09/0338

Cold Formed Anchor Channel for Regular Static Loads

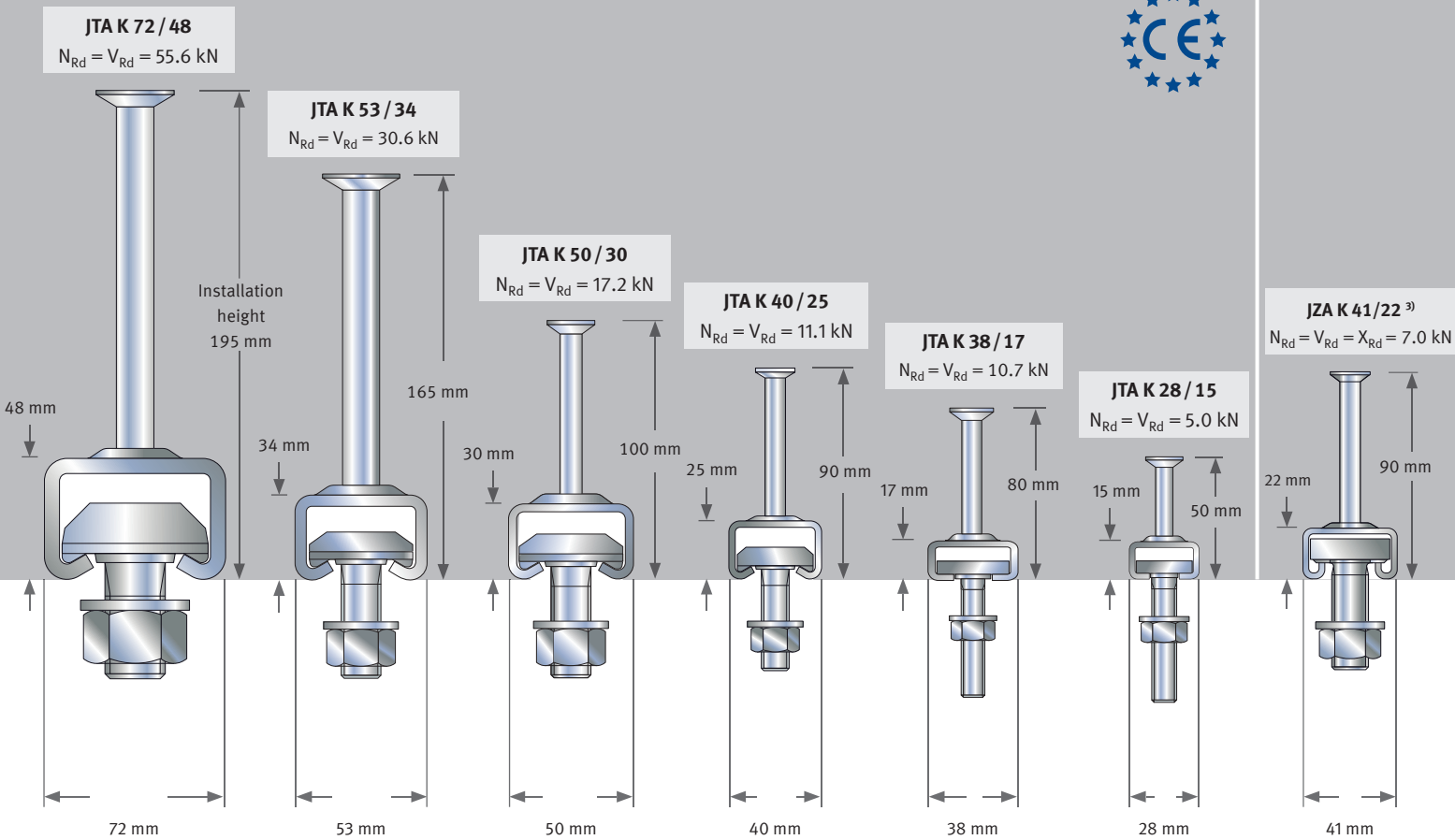

## Bolts

JA	JB	JB	JC	JH	JZS	JD
M 20	M 10	M 10	M 10	M 10		M 6
M 24	M 12	M 12	M 12	M 12	M 12	M 8
M 27	M 16	M 16	M 16	M 16	M 16	M 10
M 30	M 20	M 20				M 12

$N_{Rd}$  = Design value for axial force  
 $V_{Rd}$  = Design value for shear force

01-2012 / 2. / 11-2012 / AZ / 200 / LIT-PP-B-EN

**JORDAHL GmbH**  
Nobelstrasse 51  
12057 Berlin  
Germany

info@jordahl.de  
www.jordahl.de