

COMPACT BEARING S 65

Structural bearing for static structural members

Design values

The bearings are dimensioned according to the general building authority approval up to a compressive stress $\sigma_{R,d} = 14 \text{ N/mm}^2$. The design concept is based on the shape factor. Holes, cut-outs and the required edge distances must be taken into account according to DIN EN 1992.

TYPE OF LOAD ACTING

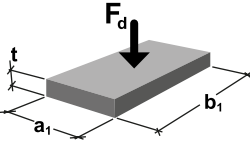
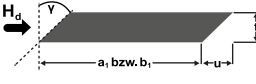
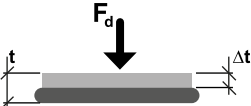
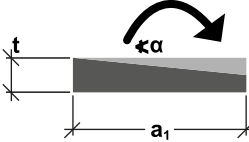
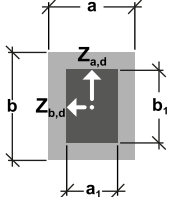
Design value of bearing resistance	All. shear deformation	Deflection	Allowable rotation	Transverse tensile forces*
				

FORMULA

$\sigma_{R,d} = 4.03 \cdot S^{1.16} \leq 14 \text{ [N/mm}^2\text{]}$	all. $u = 0.6 \cdot (t-2) \text{ [mm]}$		all. $\alpha = \frac{450 \cdot t}{a_1} \leq 40 \text{ [‰]}$ (Rectangular bearing)	$Z_{a,d} = 1.5 \cdot F_d \cdot t / b_1 \text{ [kN]}$ (perpendicular to bearing short side)
Shape factor S see page 2	Horizontal force $H_d = c_{s(t)} \cdot u \cdot A_E / 20000 \text{ [kN]}$ A minimum compressive stress of 1 N/mm^2 is required to prevent the bearing from slipping. $c_{s(t)}$ values and boundary conditions, see page 9	See page 7	Additional rotation acc. to technical approval: <ul style="list-style-type: none"> • 10 ‰ from obliquity • $\frac{625}{a_1}$ from unevenness see also booklet 600, DAfStb	$Z_{b,d} = 1.5 \cdot F_d \cdot t / a_1 \text{ [kN]}$ (perpendicular to bearing long side)
				*see also booklet 339, DAfStb

LEGEND FORMULA SYMBOLS

F_d	Vertical force	$\sigma_{R,d}$	Design value of the load capacity
H_d	Horizontal force	$\sigma_{E,d}$	Design compressive stress from load
$Z_{a,d}, Z_{b,d}$	Transverse tensile force	α	Bearing rotation
A_E	Bearing area	$c_{s(t)}$	Shear stiffness
S	Shape factor, Ratio of pressed bearing surface A_E to unloaded lateral surface	u	Shear deformation of the bearing
a_1	Short side of bearing	Y	Push angle
b_1	Long side of bearing	t	Thickness of bearing
a	Component width	Δt	Bearing deflection
b	Component length		

COMPACT BEARING S 65

Structural bearing for static structural members

Design of the shape factor

For the design of unreinforced elastomeric bearings, the shape factor S is defined as the ratio of the compressed to the freely deformable surface. The shape factor S is used to calculate the permissible compressive stress as a function of the bearing dimensions.

SHAPE FACTOR FOR RECTANGULAR BEARING

Without drilled holes

$$S = \frac{b_1 \cdot a_1}{2 \cdot t \cdot (b_1 + a_1)}$$

With drilled holes, $n \leq 2$

$$S = \frac{a \cdot b - \frac{\pi}{4} n \cdot d^2}{2 \cdot t \cdot (a+b) + t \cdot \pi \cdot n \cdot d}$$

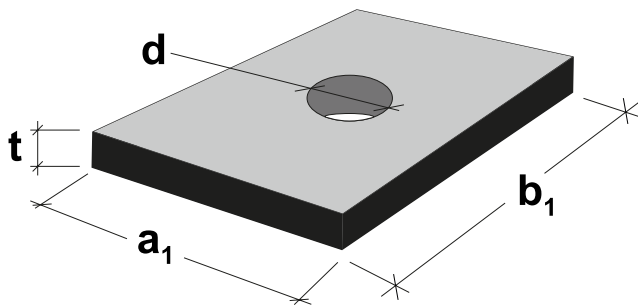

SHAPE FACTOR FOR BEARING STRIP

$$S = \frac{a_1}{2 \cdot t} \quad b_1 \gg a_1$$

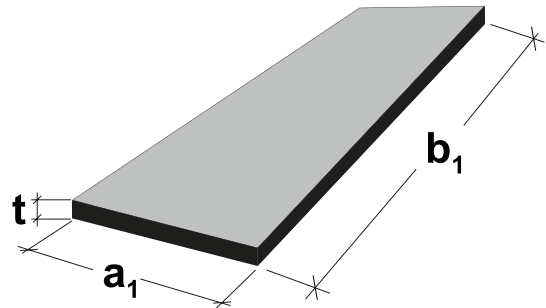

SHAPE FACTOR FOR CIRCULAR BEARING

Without drilled holes

$$S = \frac{D}{4 \cdot \sqrt{2} \cdot t}$$

With drilled holes

$$S = \frac{D-d}{4 \cdot \sqrt{2} \cdot t}$$

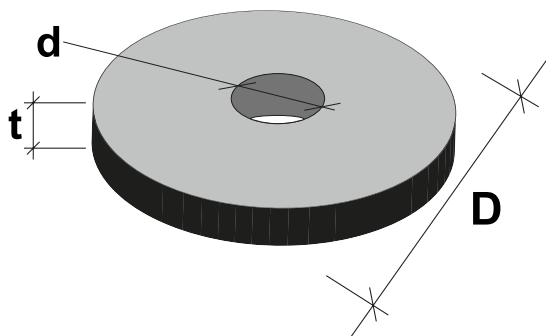

COMPACT BEARING S 65

Structural bearing for static structural members

Thicknesses: 10 and 15 mm

The following tables show the design value of the load capacity and the allowable angle of distortion as a function of the bearing dimensions. Intermediate values may be interpolated.

BEARING			DESIGN VALUE OF THE LOAD CAPACITY, $\sigma_{R,d}$ [N/mm ²]																				
[mm]	α [‰]	[mm]	BEARING LENGTH [mm]																				
Thick-ness	all. rotation	Width	70	80	90	100	110	120	130	140	150	175	200	225	250	275	300	350	400	450	500		
10		40.0	50	-	-	-	7.3	7.6	7.8	8.0	8.2	8.4	8.7	9.0	9.2	9.4	9.6	9.8	10.0	10.2	10.3	10.4	
		40.0	60	-	-	-	8.4	8.7	9.0	9.3	9.5	9.8	10.2	10.6	11.0	11.2	11.5	11.7	12.0	12.3	12.5	12.6	
		40.0	70	7.7	8.3	8.8	9.3	9.7	10.1	10.5	10.8	11.1	11.7	12.2	12.6	12.9	13.2	13.5					
		40.0	80	8.3	9.0	9.6	10.2	10.7	11.1	11.5	11.9	12.3	13.0	13.6									
		40.0	90	8.8	9.6	10.3	11.0	11.5	12.1	12.5	13.0	13.4											
		40.0	100	9.3	10.2	11.0	11.7	12.3	12.9	13.4	13.9												
		40.0	110	9.7	10.7	11.5	12.3	13.0	13.7														
		37.5	120	10.1	11.1	12.1	12.9	13.7															
		34.6	130	10.5	11.5	12.5	13.4																
		32.1	140	10.8	11.9	13.0	13.9																
		30.0	150	11.1	12.3	13.4																	
		28.1	160	11.3	12.6	13.7																	
		25.7	175	11.7	13.0																		
		22.5	200	12.2	13.6																		
		18.0	250	12.9																			
		15.0	300	13.5																			
		12.9	350	13.9																			
		11.3	400																				
		10.0	450																				
	9.0	500																					
	8.2	550																					
	7.5	600																					

14.0

BEARING			DESIGN VALUE OF THE LOAD CAPACITY, $\sigma_{R,d}$ [N/mm ²]																				
[mm]	α [‰]	[mm]	BEARING LENGTH [mm]																				
Thick-ness	all. rotation	Width	75	80	90	100	110	120	130	140	150	175	200	225	250	275	300	350	400	450	500		
15		40.0	70	5.0	5.2	5.6	5.8	6.1	6.4	6.6	6.8	6.9	7.3	7.6	7.9	8.1	8.3	8.5	8.8	9.0	9.2	9.3	
		40.0	80	5.4	5.7	6.0	6.4	6.7	7.0	7.2	7.5	7.7	8.2	8.6	8.9	9.2	9.4	9.6	10.0	10.2	10.5	10.6	
		40.0	90	5.8	6.0	6.5	6.9	7.2	7.6	7.9	8.1	8.4	9.0	9.4	9.8	10.1	10.4	10.7	11.1	11.4	11.7	12.0	
		40.0	100	6.1	6.4	6.9	7.3	7.7	8.1	8.4	8.8	9.1	9.7	10.2	10.7	11.1	11.4	11.7	12.2	12.6	13.0	13.2	
		40.0	110	6.4	6.7	7.2	7.7	8.2	8.6	9.0	9.3	9.7	10.4	11.0	11.5	12.0	12.4	12.7	13.3	13.8			
		40.0	120	6.7	7.0	7.6	8.1	8.6	9.1	9.5	9.9	10.2	11.0	11.7	12.3	12.8	13.3	13.7					
		40.0	130	6.9	7.2	7.9	8.4	9.0	9.5	9.9	10.4	10.8	11.6	12.4	13.1	13.7							
		40.0	140	7.1	7.5	8.1	8.8	9.3	9.9	10.4	10.8	11.3	12.2	13.1	13.8								
		40.0	150	7.3	7.7	8.4	9.1	9.7	10.2	10.8	11.3	11.7	12.8	13.7									
		40.0	160	7.5	7.9	8.6	9.3	10.0	10.6	11.1	11.7	12.2	13.3										
		38.6	175	7.8	8.2	9.0	9.7	10.4	11.0	11.6	12.2	12.8											
		33.8	200	8.1	8.6	9.4	10.2	11.0	11.7	12.4	13.1	13.7											
		27.0	250	8.6	9.2	10.1	11.1	12.0	12.8	13.7													
		22.5	300	9.1	9.6	10.7	11.7	12.7	13.7														
		19.3	350	9.4	10.0	11.1	12.2	13.3															
		16.9	400	9.6	10.2	11.4	12.6	13.8															
		15.0	450	9.8	10.5	11.7	13.0																
		13.5	500	10.0	10.6	12.0	13.2																
		12.3	550	10.1	10.8	12.1	13.5																
	11.3	600	10.2	10.9	12.3	13.7																	

14.0

Use in in-situ concrete: Embedding in polystyrene

Use in fire resistance class F90 / F120: If necessary, embedding in Ciflamon fire protection panel

COMPACT BEARING S 65

Structural bearing for static structural members

Thicknesses: 20 and 25mm

BEARING			DESIGN VALUE OF THE LOAD CAPACITY. $\sigma_{R,d}$ [N/mm ²]																
[mm]	α [‰]	[mm]	BEARING LENGTH [mm]																
Thick-ness	all. rotation	Width	100	110	120	125	130	140	150	175	200	225	250	275	300	350	400	450	500
			20	40.0	100	5.2	5.5	5.8	5.9	6.0	6.3	6.5	6.9	7.3	7.7	7.9	8.2	8.4	8.8
40.0	110	5.5		5.9	6.2	6.3	6.4	6.7	6.9	7.4	7.9	8.3	8.6	8.9	9.1	9.5	9.9	10.2	10.4
40.0	120	5.8		6.2	6.5	6.6	6.8	7.1	7.3	7.9	8.4	8.8	9.2	9.5	9.8	10.3	10.7	11.0	11.3
40.0	130	6.0		6.4	6.8	7.0	7.1	7.4	7.7	8.3	8.9	9.4	9.8	10.1	10.5	11.0	11.5	11.8	12.2
40.0	140	6.3		6.7	7.1	7.2	7.4	7.8	8.1	8.8	9.4	9.9	10.3	10.7	11.1	11.7	12.2	12.7	13.0
40.0	150	6.5		6.9	7.3	7.5	7.7	8.1	8.4	9.2	9.8	10.4	10.9	11.3	11.7	12.4	13.0	13.4	13.8
40.0	160	6.7		7.1	7.6	7.8	8.0	8.4	8.7	9.5	10.2	10.8	11.4	11.9	12.3	13.1	13.7		
40.0	175	6.9		7.4	7.9	8.1	8.3	8.8	9.2	10.0	10.8	11.5	12.1	12.7	13.2				
40.0	200	7.3		7.9	8.4	8.6	8.9	9.4	9.8	10.8	11.7	12.5	13.2	13.9					
36.0	250	7.9		8.6	9.2	9.5	9.8	10.3	10.9	12.1	13.2								
30.0	300	8.4		9.1	9.8	10.1	10.5	11.1	11.7	13.2									
25.7	350	8.8		9.5	10.3	10.7	11.0	11.7	12.4										
22.5	400	9.1		9.9	10.7	11.1	11.5	12.2	13.0										
20.0	450	9.3		10.2	11.0	11.4	11.8	12.7	13.4										
18.0	500	9.5		10.4	11.3	11.7	12.2	13.0	13.8										
16.4	550	9.7		10.6	11.5	12.0	12.4	13.3											
15.0	600	9.8	10.8	11.7	12.2	12.7	13.6												

14.0

Use in in-situ concrete: Embedding in polystyrene

Use in fire resistance class F90 / F120: If necessary, embedding in Ciflamon fire protection panel

BEARING			DESIGN VALUE OF THE LOAD CAPACITY. $\sigma_{R,d}$ [N/mm ²]													
[mm]	α [‰]	[mm]	BEARING LENGTH [mm]													
Thick-ness	all. rotation	Width	125	130	140	150	175	200	225	250	275	300	350	400	450	500
			25	40.0	125	5.2	5.4	5.6	5.8	6.3	6.7	7.0	7.3	7.6	7.8	8.2
40.0	130	5.4		5.5	5.7	5.9	6.4	6.9	7.2	7.5	7.8	8.1	8.5	8.9	9.1	9.4
40.0	140	5.6		5.7	6.0	6.2	6.8	7.2	7.6	8.0	8.3	8.6	9.1	9.4	9.8	10.0
40.0	150	5.8		5.9	6.2	6.5	7.1	7.6	8.0	8.4	8.7	9.1	9.6	10.0	10.4	10.7
40.0	160	6.0		6.2	6.4	6.7	7.4	7.9	8.4	8.8	9.2	9.5	10.1	10.6	11.0	11.3
40.0	175	6.3		6.4	6.8	7.1	7.8	8.4	8.9	9.4	9.8	10.2	10.8	11.4	11.8	12.2
40.0	200	6.7		6.9	7.2	7.6	8.4	9.1	9.7	10.2	10.7	11.2	12.0	12.6	13.2	13.7
40.0	250	7.3		7.5	8.0	8.4	9.4	10.2	11.0	11.7	12.4	13.0				
37.5	300	7.8		8.1	8.6	9.1	10.2	11.2	12.1	13.0	13.8					
32.1	350	8.2		8.5	9.1	9.6	10.8	12.0	13.0							
28.1	400	8.6		8.9	9.4	10.0	11.4	12.6	13.8							
25.0	450	8.8		9.1	9.8	10.4	11.8	13.2								
22.5	500	9.1		9.4	10.0	10.7	12.2	13.7								
20.5	550	9.2		9.6	10.3	11.0	12.6									
18.8	600	9.4		9.8	10.5	11.2	12.9									

14.0

Use in in-situ concrete: Embedding in polystyrene

Use in fire resistance class F90 / F120: If necessary, embedding in Ciflamon fire protection panel

COMPACT BEARING S 65

Structural bearing for static structural members

Thickness: 30 mm

BEARING			DESIGN VALUE OF THE LOAD CAPACITY. $\sigma_{R,d}$ [N/mm ²]										
[mm]	α [‰]	[mm]	BEARING LENGTH [mm]										
Thick-ness	all. rotation	Width	150	175	200	225	250	275	300	350	400	450	500
30	40.0	150	5.2	5.7	6.1	6.5	6.8	7.1	7.3	7.8	8.1	8.4	8.6
	40.0	160	5.4	5.9	6.4	6.8	7.1	7.4	7.7	8.2	8.6	8.9	9.2
	40.0	175	5.7	6.3	6.8	7.2	7.6	7.9	8.2	8.8	9.2	9.6	9.9
	40.0	200	6.1	6.8	7.3	7.8	8.3	8.7	9.1	9.7	10.2	10.7	11.1
	40.0	250	6.8	7.6	8.3	8.9	9.5	10.0	10.5	11.3	12.1	12.7	13.2
	40.0	300	7.3	8.2	9.1	9.8	10.5	11.1	11.7	12.8	13.7		
	38.6	350	7.8	8.8	9.7	10.5	11.3	12.1	12.8				
	33.8	400	8.1	9.2	10.2	11.2	12.1	12.9	13.7				
	30.0	450	8.4	9.6	10.7	11.7	12.7	13.6					
	27.0	500	8.6	9.9	11.1	12.2	13.2						
	24.5	550	8.9	10.2	11.4	12.6	13.7						
	22.5	600	9.1	10.4	11.7	13.0							

14.0

Use in in-situ concrete: Embedding in polystyrene

Use in fire resistance class F90 / F120: If necessary, embedding in Ciflamon fire protection panel

COMPACT BEARING S 65

Structural bearing for static structural members

Thicknesses: 10, 15, 20, 25 and 30 mm

STRIP BEARINGS										
COMPACT BEARING S 65										
BEARING WIDTH a_1 [mm]	BEARING THICKNESSES									
	t = 10 mm		t = 15 mm		t = 20 mm		t = 25 mm		t = 30 mm	
	$F_{R,d}$	all. α	$F_{R,d}$	all. α	$F_{R,d}$	all. α	$F_{R,d}$	all. α	$F_{R,d}$	all. α
	[kN/m]	[‰]	[kN/m]	[‰]	[kN/m]	[‰]	[kN/m]	[‰]	[kN/m]	[‰]
50	583	40	-	-	-	-	-	-	-	-
60	840	40	-	-	-	-	-	-	-	-
70	980	40	-	-	-	-	-	-	-	-
80	1120	40	1006	40	-	-	-	-	-	-
90	1260	40	1260	40	-	-	-	-	-	-
100	1400	40	1400	40	1167	40	-	-	-	-
110	1540	40	1540	40	1433	40	-	-	-	-
120	1680	37.5	1680	40	1680	40	-	-	-	-
130	1820	34.6	1820	40	1820	40	1587	40	-	-
140	1960	32.1	1960	40	1960	40	1863	40	-	-
150	2100	30.0	2100	40	2100	40	2100	40	1750	40
160	2240	28.1	2240	40	2240	40	2240	40	2012	40
170	2380	26.5	2380	39.7	2380	40	2380	40	2293	40
180	2520	25.0	2520	37.5	2520	40	2520	40	2520	40
190	2660	23.7	2660	35.5	2660	40	2660	40	2660	40
200	2800	22.5	2800	33.8	2800	40	2800	40	2800	40
210	2940	21.4	2940	32.1	2940	40	2940	40	2940	40
220	3080	20.5	3080	30.7	3080	40	3080	40	3080	40
230	3220	19.6	3220	29.3	3220	39.1	3220	40	3220	40
240	3360	18.8	3360	28.1	3360	37.5	3360	40	3360	40
250	3500	18.0	3500	27.0	3500	36.0	3500	40	3500	40

Use in in-situ concrete: Embedding in polystyrene
 Use in fire resistance class F90 / F120: If necessary, embedding in Ciflamon fire protection panel

COMPACT BEARING S 65

Structural bearing for static structural members

Load deflection curves

The following diagrams show the compression behaviour for different formats when used between concrete surfaces (precast elements).

Thickness 10 mm

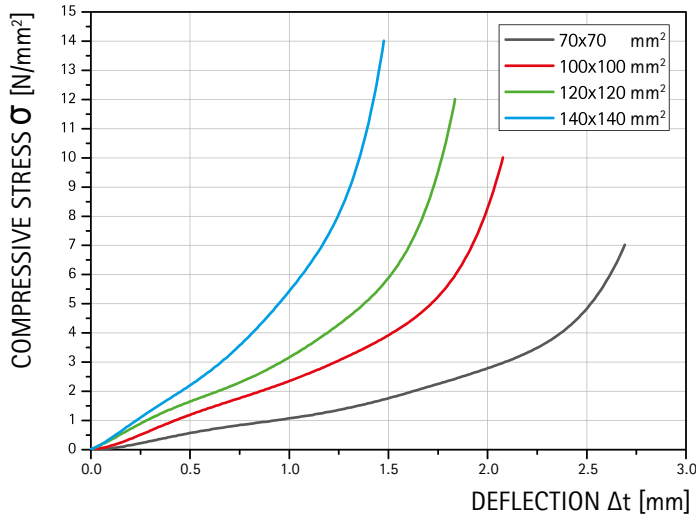

Thickness 15 mm

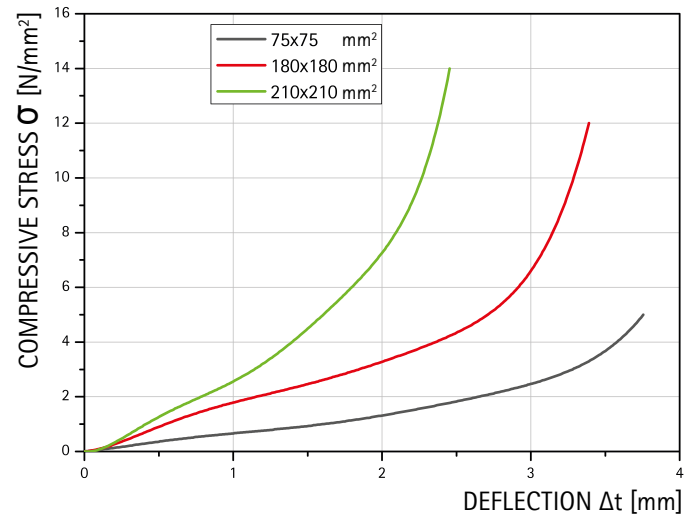

Thickness 20 mm

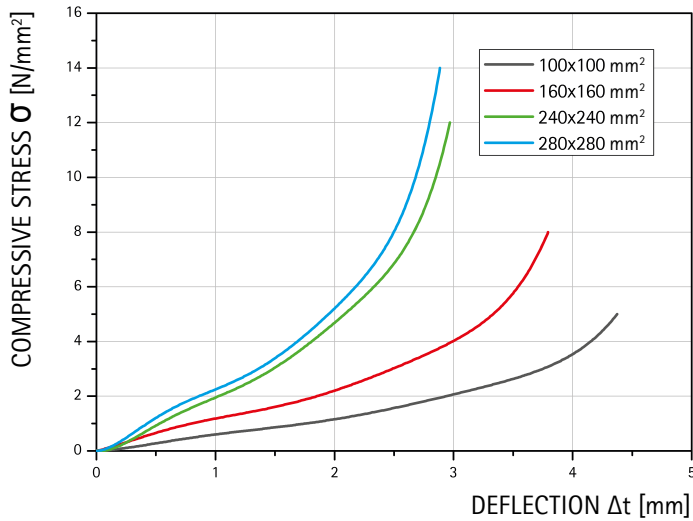

Thickness 25 mm

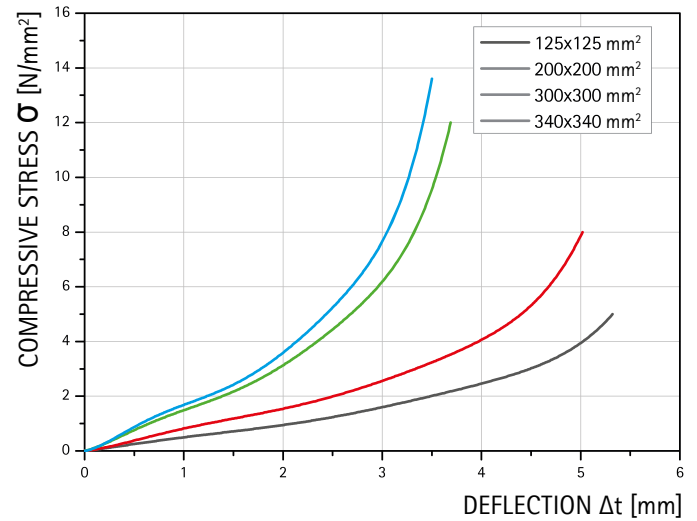

Thickness 30 mm

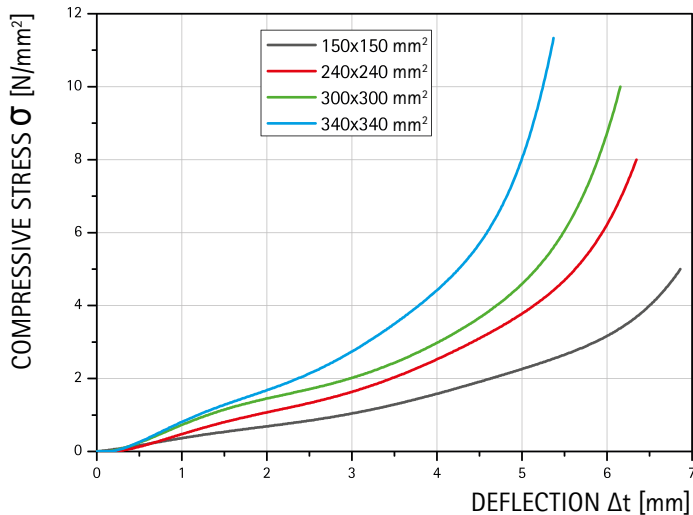

COMPACT BEARING S 65

Structural bearing for static structural members

Design example

Given: $F_{E,k} = 590 \text{ kN}$ corresponding to $F_{E,d} = 1.4 \times F_{E,k} = 826 \text{ kN}^*$, bearing rotation $\alpha = 19 \text{ ‰}$, horizontal deformation $u = 6.2 \text{ mm}$

Selected dimensions:

$$a_1 = 160 \text{ mm}, b_1 = 370 \text{ mm}, t = 15 \text{ mm}$$

Shape factor:

$$S = \frac{160 \text{ mm} \times 370 \text{ mm}}{2 \times 15 \text{ mm} \times (160 \text{ mm} + 370 \text{ mm})} = 3,7$$

Load capacity:

$$\sigma_{R,d} = 4.03 \times 3.7^{1.16} = 18.4 \text{ N/mm}^2 > 14 \text{ N/mm}^2$$

$$\rightarrow \sigma_{R,d} = 14 \text{ N/mm}^2$$

$$F_{R,d} = \sigma_{R,d} \times A_E = 14.0 \text{ N/mm}^2 \times 160 \text{ mm} \times 370 \text{ mm} = 828.8 \text{ kN}$$

$$F_{R,d} \geq F_{E,d} \rightarrow \text{Load capacity of the bearing is sufficient}$$

Bearing distortion from component deflection: $\alpha = 19 \text{ ‰}$

Additional twisting from obliquity:

$$10 \text{ ‰}$$

Additional twisting from unevenness:

$$625 \text{ (mm*‰)} / a \text{ (mm)} = 625 / 160 \text{ ‰} = 3.9 \text{ ‰}$$

Total rotation to be measured:

$$\alpha = 19 \text{ ‰} + 10 \text{ ‰} + 3.9 \text{ ‰} = 32.2 \text{ ‰}$$

$$\text{max. } \alpha = 450 \text{ ‰} \times t/a = 450 \text{ ‰} \times 15 \text{ mm} / 160 \text{ mm} = 42.2 \text{ ‰} > 40 \text{ ‰}$$

$$\rightarrow \text{max. } \alpha = 40 \text{ ‰}$$

$$\text{max. } \alpha \geq \alpha \rightarrow \text{Angle of twist for rotation is sufficient}$$

Horizontal deformation of structural members: $u = 6.2 \text{ mm}$

$$\text{max. } u = 0.6 \times (t-2) = 7.8 \text{ mm}$$

$$\text{max. } u \geq u \rightarrow \text{Shear deformability of the bearing is sufficient}$$

* Note on partial safety factor: The partial safety factor of a compressive load depends on its type. In case of permanent loads it is e.g. 1.35, in case of variable loads 1.5. Since structural bearings in building construction should only be used under predominantly permanent loads, a factor of approximately 1.4 can be used for the ratio between the total characteristic load and the total design rated load.

COMPACT BEARING S 65

Structural bearing for static structural members

Shear stiffness

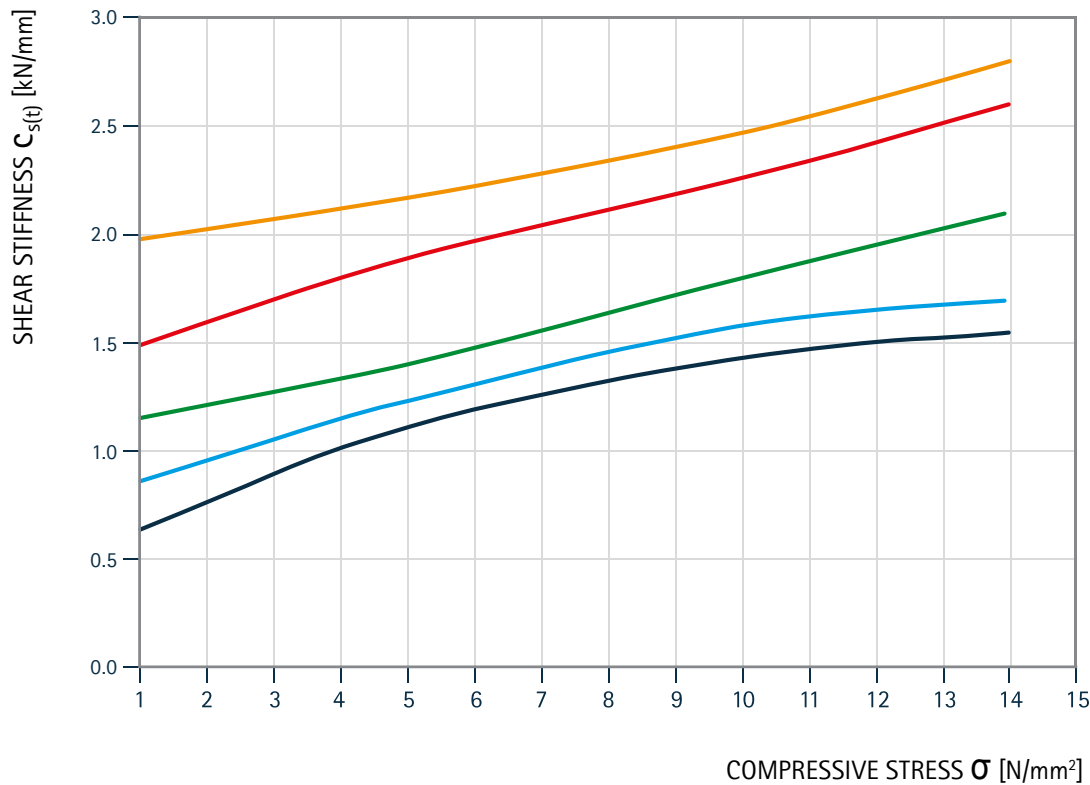

SHEAR STIFFNESS CURVE

- 10 mm
- 15 mm
- 20 mm
- 25 mm
- 30 mm

DIAGRAM

For the horizontal shear deformation from uniquely acting horizontal forces, no verification is required, since uniquely slight sliding does not lead to any damaging changes in the structural layout. If the thrust deflection is to be a „pure“ shear deformation, a vertical bearing compressive stress $\sigma_{E,d}$ of at least 1 N/mm² is required.

The contents of this publication are the result of many years of research and experience gained in the application of this technology. All information is given in good faith; it does not represent a guarantee with respect to characteristics and does not exempt the user from testing the suitability of products and from ascertaining that the industrial property rights of third parties are not violated. No liability whatsoever will be accepted for damage – regardless of its nature and its legal basis – arising from advice given in this publication. We reserve the right to make technical modifications in the course of product development.

© Copyright – Calenberg Ingenieure GmbH – 2022

Version 4

7 February 2022

Calenberg Ingenieure GmbH | Am Knübel 2-4 | 31020 Salzhemmendorf | Germany | info@calenberg-ingenieure.de | www.calenberg-ingenieure.de