

COMPACT BEARING S 70

Structural bearing for static structural members

Design values

The bearings are dimensioned according to the general building authority approval up to a compressive stress $\sigma_{R,d} = 21 \text{ N/mm}^2$. The design concept is based on the shape factor. Holes, cut-outs and the required edge distances must be taken into account according to DIN EN 1992.

TYPE OF LOAD ACTING

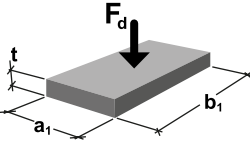
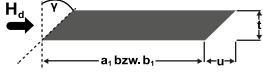
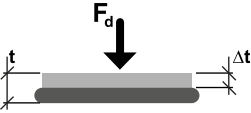
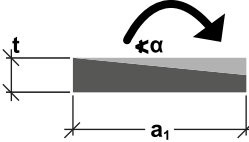
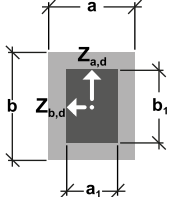
Design value of bearing resistance	All. shear deformation	Deflection	Allowable rotation	Transverse tensile forces*
				

FORMEL

$\sigma_{R,d} = 7 \cdot S \leq 21 \text{ [N/mm}^2\text{]}$ Note: Formula in the data sheet in the sense of a simpler application slightly modified Shape factor S see page 2	all. $u = 0,6 \cdot (t-2) \text{ [mm]}$ Horizontal force $H_d = c_{s(t)} \cdot u \cdot A_E / 20000 \text{ [kN]}$ A minimum compressive stress of 2 N/mm^2 is required to prevent the bearing from slipping. $c_{s(t)}$ values and boundary conditions, see page 8	See page 6	all. $\alpha = \frac{450 \cdot t}{a_1} \leq 40 \text{ [‰]}$ (Rectangular bearing) Additional rotation acc. to technical approval: • 10 ‰ from obliquity • $\frac{625}{a_1}$ from unevenness see also booklet 600, DAfStb	$Z_{a,d} = 1,5 \cdot F_d \cdot t / b_1 \text{ [kN]}$ (perpendicular to bearing short side) $Z_{b,d} = 1,5 \cdot F_d \cdot t / a_1 \text{ [kN]}$ (perpendicular to bearing long side) *see also booklet 339, DAfStb
--------------------------------------------------------------------------------------------------------------------------------------------------------------------------------------------	----------------------------------------------------------------------------------------------------------------------------------------------------------------------------------------------------------------------------------------------------------------------------------------------	------------	-------------------------------------------------------------------------------------------------------------------------------------------------------------------------------------------------------------------------------------------------	----------------------------------------------------------------------------------------------------------------------------------------------------------------------------------------------------------------------------------------

LEGENDE FORMELZEICHEN

F_d	Vertical force	$\sigma_{R,d}$	Design value of the load capacity
H_d	Horizontal force	$\sigma_{E,d}$	Design compressive stress from load
$Z_{a,d}, Z_{b,d}$	Transverse tensile force	α	Bearing rotation
A_E	Bearing area	$c_{s(t)}$	Shear stiffness
S	Shape factor, Ratio of pressed bearing surface A_E to unloaded lateral surface	u	Shear deformation of the bearing
a_1	Short side of bearing	γ	Push angle
b_1	Long side of bearing	t	Thickness of bearing
a	Component width	Δt	Bearing deflection
b	Component length		

COMPACT BEARING S 70

Structural bearing for static structural members

Design of the shape factor

For the design of unreinforced elastomeric bearings, the shape factor S is defined as the ratio of the compressed to the freely deformable surface. The shape factor S is used to calculate the permissible compressive stress as a function of the bearing dimensions.

SHAPE FACTOR FOR RECTANGULAR BEARING

Without drilled holes

$$S = \frac{b_1 \cdot a_1}{2 \cdot t \cdot (b_1 + a_1)}$$

With drilled holes, $n \leq 2$

$$S = \frac{a \cdot b - \frac{\pi}{4} n \cdot d^2}{2 \cdot t \cdot (a + b) + t \cdot \pi \cdot n \cdot d}$$

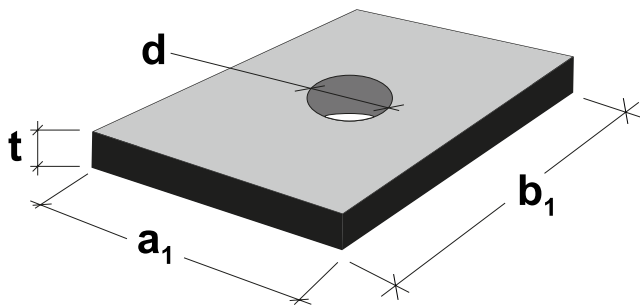

SHAPE FACTOR FOR BEARING STRIP

$$S = \frac{a_1}{2 \cdot t} \quad b_1 \gg a_1$$

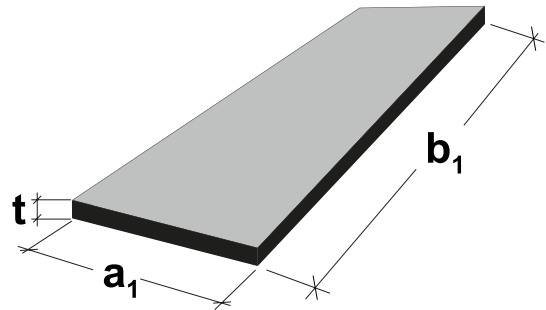

SHAPE FACTOR FOR CIRCULAR BEARING

Without drilled holes

$$S = \frac{D}{4 \cdot \sqrt{2} \cdot t}$$

With drilled holes

$$S = \frac{D - d}{4 \cdot \sqrt{2} \cdot t}$$

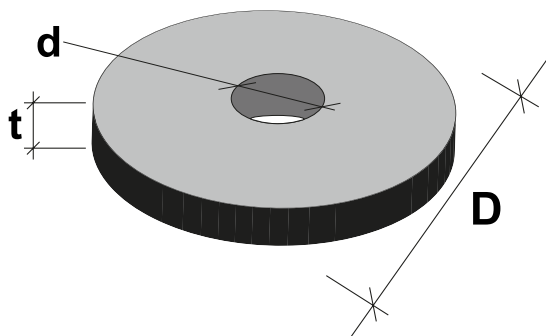

COMPACT BEARING S 70

Structural bearing for static structural members

Thicknesses: 10 and 15 mm

The following tables show the design value of the load capacity and the allowable angle of distortion as a function of the bearing dimensions. Intermediate values may be interpolated.

BEARING			DESIGN VALUE OF THE LOAD CAPACITY, $\sigma_{R,d}$ [N/mm ²]																			
[mm]	α [‰]	[mm]	BEARING LENGTH [mm]																			
Thick-ness	all. rotation	Width	70	80	90	100	110	120	130	140	150	175	200	225	250	275	300	350	400	450	500	
10		40,0	50	-	-	-	11,7	12,0	12,4	12,6	12,9	13,1	13,6	14,0	14,3	14,6	14,8	15,0	15,3	15,6	15,8	15,9
		40,0	60	-	-	-	13,1	13,6	14,0	14,4	14,7	15,0	15,6	16,2	16,6	16,9	17,2	17,5	17,9	18,3	18,5	18,8
		40,0	70	12,3	13,1	13,8	14,4	15,0	15,5	15,9	16,3	16,7	17,5	18,1	18,7	19,1	19,5	19,9	20,4	20,9		
		40,0	80	13,1	14,0	14,8	15,6	16,2	16,8	17,3	17,8	18,3	19,2	20,0	20,7							
		40,0	90	13,8	14,8	15,8	16,6	17,3	18,0	18,6	19,2	19,7	20,8									
		40,0	100	14,4	15,6	16,6	17,5	18,3	19,1	19,8	20,4											
		40,0	110	15,0	16,2	17,3	18,3	19,3	20,1	20,9												
		37,5	120	15,5	16,8	18,0	19,1	20,1														
		34,6	130	15,9	17,3	18,6	19,8	20,9														
		32,1	140	16,3	17,8	19,2	20,4															
		30,0	150	16,7	18,3	19,7																
		28,1	160	17,0	18,7	20,2																
		25,7	175	17,5	19,2	20,8																
		22,5	200	18,1	20,0																	
		18,0	250	19,1																		
		15,0	300	19,9																		
		12,9	350	20,4																		
		11,3	400	20,9																		
		10,0	450																			
	9,0	500																				
	8,2	550																				
	7,5	600																				

21,0

BEARING			DESIGN VALUE OF THE LOAD CAPACITY, $\sigma_{R,d}$ [N/mm ²]																			
[mm]	α [‰]	[mm]	BEARING LENGTH [mm]																			
Thick-ness	all. rotation	Width	75	80	90	100	110	120	130	140	150	175	200	225	250	275	300	350	400	450	500	
15		40,0	75	8,8	9,0	9,5	10,0	10,4	10,8	11,1	11,4	11,7	12,3	12,7	13,1	13,5	13,8	14,0	14,4	14,7	15,0	15,2
		40,0	80	9,0	9,3	9,9	10,4	10,8	11,2	11,6	11,9	12,2	12,8	13,3	13,8	14,1	14,5	14,7	15,2	15,6	15,8	16,1
		40,0	90	9,5	9,9	10,5	11,1	11,6	12,0	12,4	12,8	13,1	13,9	14,5	15,0	15,4	15,8	16,2	16,7	17,1	17,5	17,8
		40,0	100	10,0	10,4	11,1	11,7	12,2	12,7	13,2	13,6	14,0	14,8	15,6	16,2	16,7	17,1	17,5	18,1	18,7	19,1	19,4
		40,0	110	10,4	10,8	11,6	12,2	12,8	13,4	13,9	14,4	14,8	15,8	16,6	17,2	17,8	18,3	18,8	19,5	20,1	20,6	
		40,0	120	10,8	11,2	12,0	12,7	13,4	14,0	14,6	15,1	15,6	16,6	17,5	18,3	18,9	19,5	20,0	20,9			
		40,0	130	11,1	11,6	12,4	13,2	13,9	14,6	15,2	15,7	16,3	17,4	18,4	19,2	20,0	20,6					
		40,0	140	11,4	11,9	12,8	13,6	14,4	15,1	15,7	16,3	16,9	18,1	19,2	20,1	20,9						
		40,0	150	11,7	12,2	13,1	14,0	14,8	15,6	16,3	16,9	17,5	18,8	20,0								
		40,0	160	11,9	12,4	13,4	14,4	15,2	16,0	16,7	17,4	18,1	19,5	20,7								
		38,6	175	12,3	12,8	13,9	14,8	15,8	16,6	17,4	18,1	18,8	20,4									
		33,8	200	12,7	13,3	14,5	15,6	16,6	17,5	18,4	19,2	20,0										
		27,0	250	13,5	14,1	15,4	16,7	17,8	18,9	20,0	20,9											
		22,5	300	14,0	14,7	16,2	17,5	18,8	20,0													
		19,3	350	14,4	15,2	16,7	18,1	19,5	20,9													
		16,9	400	14,7	15,6	17,1	18,7	20,1														
		15,0	450	15,0	15,8	17,5	19,1	20,6														
		13,5	500	15,2	16,1	17,8	19,4															
		12,3	550	15,4	16,3	18,0	19,7															
	11,3	600	15,6	16,5	18,3	20,0																

21,0

Use in in-situ concrete: Embedding in polystyrene

Use in fire resistance class F90 / F120: If necessary, embedding in Ciflamon fire protection panel

COMPACT BEARING S 70

Structural bearing for static structural members

Thickness: 20 mm

BEARING			DESIGN VALUE OF THE LOAD CAPACITY, $\sigma_{R,d}$ [N/mm ²]																
[mm]	α [‰]	[mm]	BEARING LENGTH [mm]																
Thick- ness	all- rotation	Width	100	110	120	125	130	140	150	175	200	225	250	275	300	350	400	450	500
			20	40,0	100	8,8	9,2	9,5	9,7	9,9	10,2	10,5	11,1	11,7	12,1	12,5	12,8	13,1	13,6
40,0	110	9,2		9,6	10,0	10,2	10,4	10,8	11,1	11,8	12,4	12,9	13,4	13,8	14,1	14,6	15,1	15,5	15,8
40,0	120	9,5		10,0	10,5	10,7	10,9	11,3	11,7	12,5	13,1	13,7	14,2	14,6	15,0	15,6	16,2	16,6	16,9
40,0	130	9,9		10,4	10,9	11,2	11,4	11,8	12,2	13,1	13,8	14,4	15,0	15,4	15,9	16,6	17,2	17,7	18,1
40,0	140	10,2		10,8	11,3	11,6	11,8	12,3	12,7	13,6	14,4	15,1	15,7	16,2	16,7	17,5	18,1	18,7	19,1
40,0	150	10,5		11,1	11,7	11,9	12,2	12,7	13,1	14,1	15,0	15,8	16,4	17,0	17,5	18,4	19,1	19,7	20,2
40,0	160	10,8		11,4	12,0	12,3	12,6	13,1	13,5	14,6	15,6	16,4	17,1	17,7	18,3	19,2	20,0	20,7	
40,0	175	11,1		11,8	12,5	12,8	13,1	13,6	14,1	15,3	16,3	17,2	18,0	18,7	19,3	20,4			
40,0	200	11,7		12,4	13,1	13,5	13,8	14,4	15,0	16,3	17,5	18,5	19,4	20,3					
36,0	250	12,5		13,4	14,2	14,6	15,0	15,7	16,4	18,0	19,4	20,7							
30,0	300	13,1		14,1	15,0	15,4	15,9	16,7	17,5	19,3									
25,7	350	13,6		14,6	15,6	16,1	16,6	17,5	18,4	20,4									
22,5	400	14,0		15,1	16,2	16,7	17,2	18,1	19,1										
20,0	450	14,3		15,5	16,6	17,1	17,7	18,7	19,7										
18,0	500	14,6		15,8	16,9	17,5	18,1	19,1	20,2										
16,4	550	14,8	16,0	17,2	17,8	18,4	19,5	20,6											
15,0	600	15,0	16,3	17,5	18,1	18,7	19,9												

21,0

Use in in-situ concrete: Embedding in polystyrene

Use in fire resistance class F90 / F120: If necessary, embedding in Ciflamon fire protection panel

COMPACT BEARING S 70

Structural bearing for static structural members

STRIP BEARINGS

BEARING WIDTH a_1		COMPACT BEARING S 70					
		BEARING THICKNESSES					
a_1 [mm]		t = 10 mm		t = 15 mm		t = 20 mm	
		$F_{R,d}$ [kN/m]	all. α [‰]	$F_{R,d}$ [kN/m]	all. α [‰]	$F_{R,d}$ [kN/m]	all. α [‰]
50		875	40,0	-	-	-	-
60		1260	40,0	-	-	-	-
70		1470	40,0	-	-	-	-
80		1680	40,0	1493	40,0	-	-
90		1890	40,0	1890	40,0	-	-
100		2100	40,0	2100	40,0	1750	40,0
110		2310	40,0	2310	40,0	2118	40,0
120		2520	37,5	2520	40,0	2520	40,0
130		2730	34,6	2730	40,0	2730	40,0
140		2940	32,1	2940	40,0	2940	40,0
150		3150	30,0	3150	40,0	3150	40,0
160		3360	28,1	3360	40,0	3360	40,0
170		3570	26,5	3570	39,7	3570	40,0
180		3780	25,0	3780	37,5	3780	40,0
190		3990	23,7	3990	35,5	3990	40,0
200		4200	22,5	4200	33,8	4200	40,0
210		4410	21,4	4410	32,1	4410	40,0
220		4620	20,5	4620	30,7	4620	40,0
230		4830	19,6	4830	29,3	4830	39,1
240		5040	18,8	5040	28,1	5040	37,5
250		5250	18,0	5250	27,0	5250	36,0

Use in in-situ concrete: Embedding in polystyrene

Use in fire resistance class F90 / F120: If necessary, embedding in Ciflamon fire protection panel

COMPACT BEARING S 70

Structural bearing for static structural members

Load deflection curves

The following diagrams show the compression behaviour for different formats when used between concrete surfaces (precast elements).

Thickness 10 mm

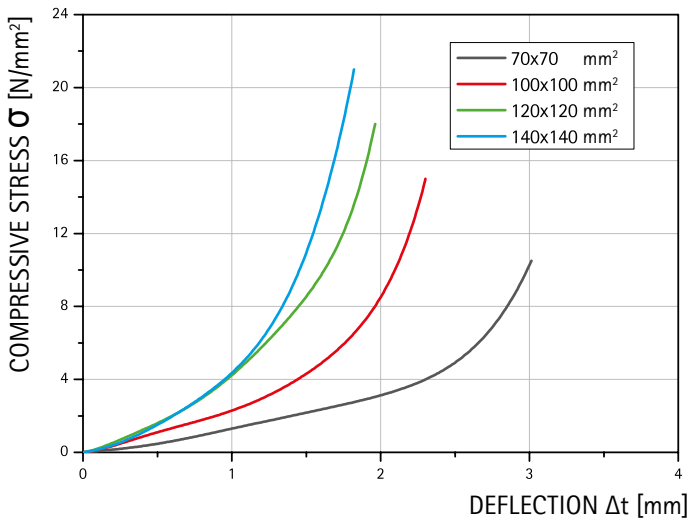

Thickness 15 mm

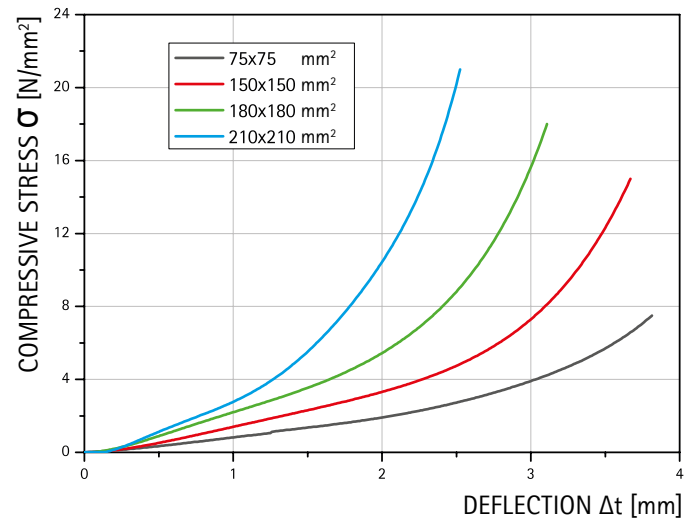

Thickness 20 mm

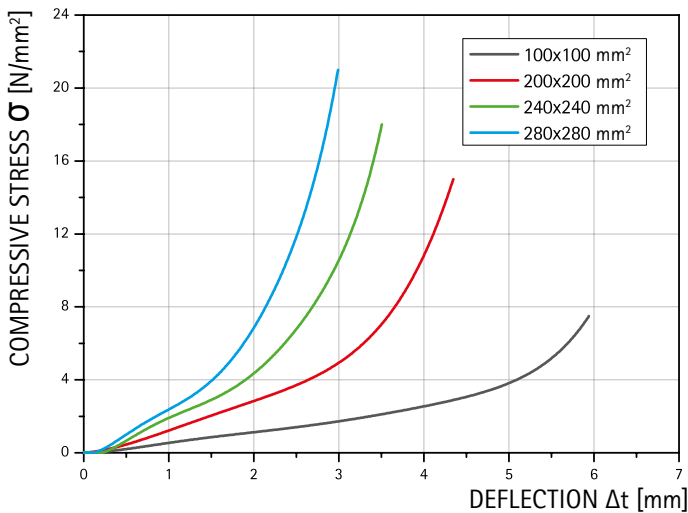

Thickness 10 mm, behaviour at very high σ

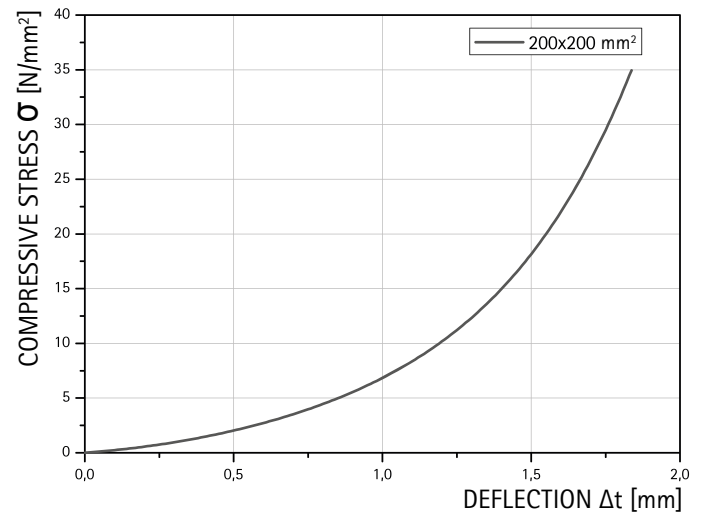

Load deflection curve up to the design value of load capacity acc. to the approval for a bearing of this type with high shape factor.

COMPACT BEARING S 70

Structural bearing for static structural members

Design example

Given: $F_{E,k} = 880 \text{ kN}$ corresponding to $F_{E,d} = 1,4 \times F_{E,k} = 1232 \text{ kN}^*$, bearing rotation $\alpha = 19 \text{ ‰}$, horizontal deformation $u = 6,2 \text{ mm}$

Selected dimensions:

$$a_1 = 160 \text{ mm}, b_1 = 370 \text{ mm}, t = 15 \text{ mm}$$

Shape factor:

$$S = \frac{160 \text{ mm} \times 370 \text{ mm}}{2 \times 15 \text{ mm} \times (160 \text{ mm} + 370 \text{ mm})} = 3,7$$

Load capacity:

$$\sigma_{R,d} = 7 \times 3,7 = 25,9 \text{ N/mm}^2 > 21,0 \text{ N/mm}^2$$

$$\rightarrow \sigma_{R,d} = 21 \text{ N/mm}^2$$

$$F_{R,d} = \sigma_{R,d} \times A_E = 21,0 \text{ N/mm}^2 \times 160 \text{ mm} \times 370 \text{ mm} = 1243,2 \text{ kN}$$

$$F_{R,d} \geq F_{E,d} \rightarrow \text{Load capacity of the bearing is sufficient}$$

Bearing distortion from component deflection: $\alpha = 19 \text{ ‰}$

Additional twisting from obliquity: 10 ‰

Additional twisting from unevenness:

$$625 \text{ (mm}^* \text{ ‰)} / a \text{ (mm)} = 625 / 160 = 3,9 \text{ ‰}$$

Total rotation to be measured:

$$\alpha = 19 \text{ ‰} + 10 \text{ ‰} + 3,9 \text{ ‰} = 32,9 \text{ ‰}$$

$$\text{max. } \alpha = 450 \text{ ‰} \times t/a = 450 \text{ ‰} \times 15 \text{ mm} / 160 \text{ mm} = 42,2 \text{ ‰} > 40 \text{ ‰}$$

$$\rightarrow \text{zul. } \alpha = 40 \text{ ‰}$$

$$\text{all. } \alpha \geq \alpha \rightarrow \text{Angle of twist for rotation is sufficient}$$

Horizontal deformation of structural members: $u = 6,2 \text{ mm}$

$$\text{all. } u = 0,6 \times (t-2) = 7,8 \text{ mm}$$

$$\text{all. } u \geq u \rightarrow \text{Shear deformability of the bearing is sufficient}$$

* Note on partial safety factor: The partial safety factor of a compressive load depends on its type. In case of permanent loads it is e.g. 1.35, in case of variable loads 1.5. Since structural bearings in building construction should only be used under predominantly permanent loads, a factor of approximately 1.4 can be used for the ratio between the total characteristic load and the total design rated load.

COMPACT BEARING S 70

Structural bearing for static structural members

Shear stiffness

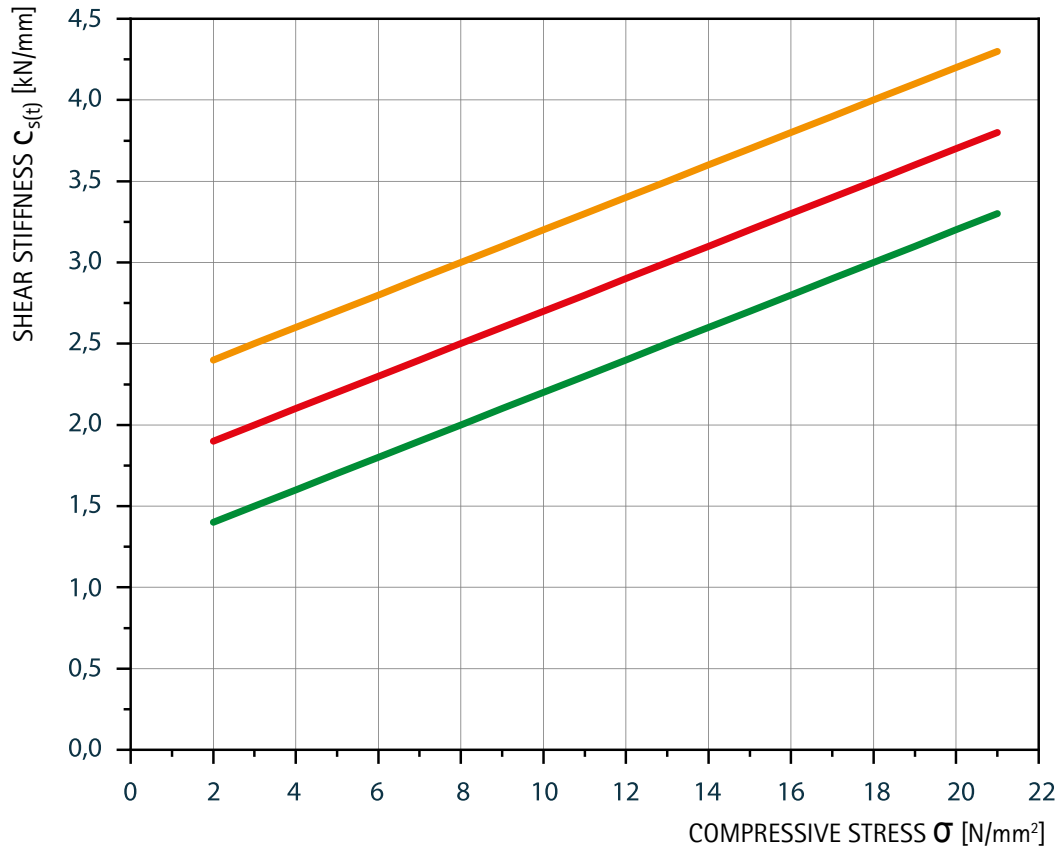

SHEAR STIFFNESS CURVE

- 10mm
- 15mm
- 20mm

DIAGRAM

For the horizontal shear deformation from uniquely acting horizontal forces, no verification is required, since uniquely slight sliding does not lead to any damaging changes in the structural layout. If the thrust deflection is to be a „pure“ shear deformation, a vertical bearing compressive stress $\sigma_{E,d}$ of at least 2 N/mm² is required.

The contents of this publication are the result of many years of research and experience gained in the application of this technology. All information is given in good faith; it does not represent a guarantee with respect to characteristics and does not exempt the user from testing the suitability of products and from ascertaining that the industrial property rights of third parties are not violated. No liability whatsoever will be accepted for damage – regardless of its nature and its legal basis – arising from advice given in this publication. We reserve the right to make technical modifications in the course of product development.

© Copyright – Calenberg Ingenieure GmbH – 2021

Version 5

9 August 2021

Calenberg Ingenieure GmbH | Am Knübel 2-4 | 31020 Salzhemmendorf | Germany | info@calenberg-ingenieure.de | www.calenberg-ingenieure.de