

# PWC and PWS wall shoe systems

Installation and  
assembly instruction

**PFEIFER**

# Overview and table of contents

## 2 systems – 1 goal:

The optimum solution for every construction project!

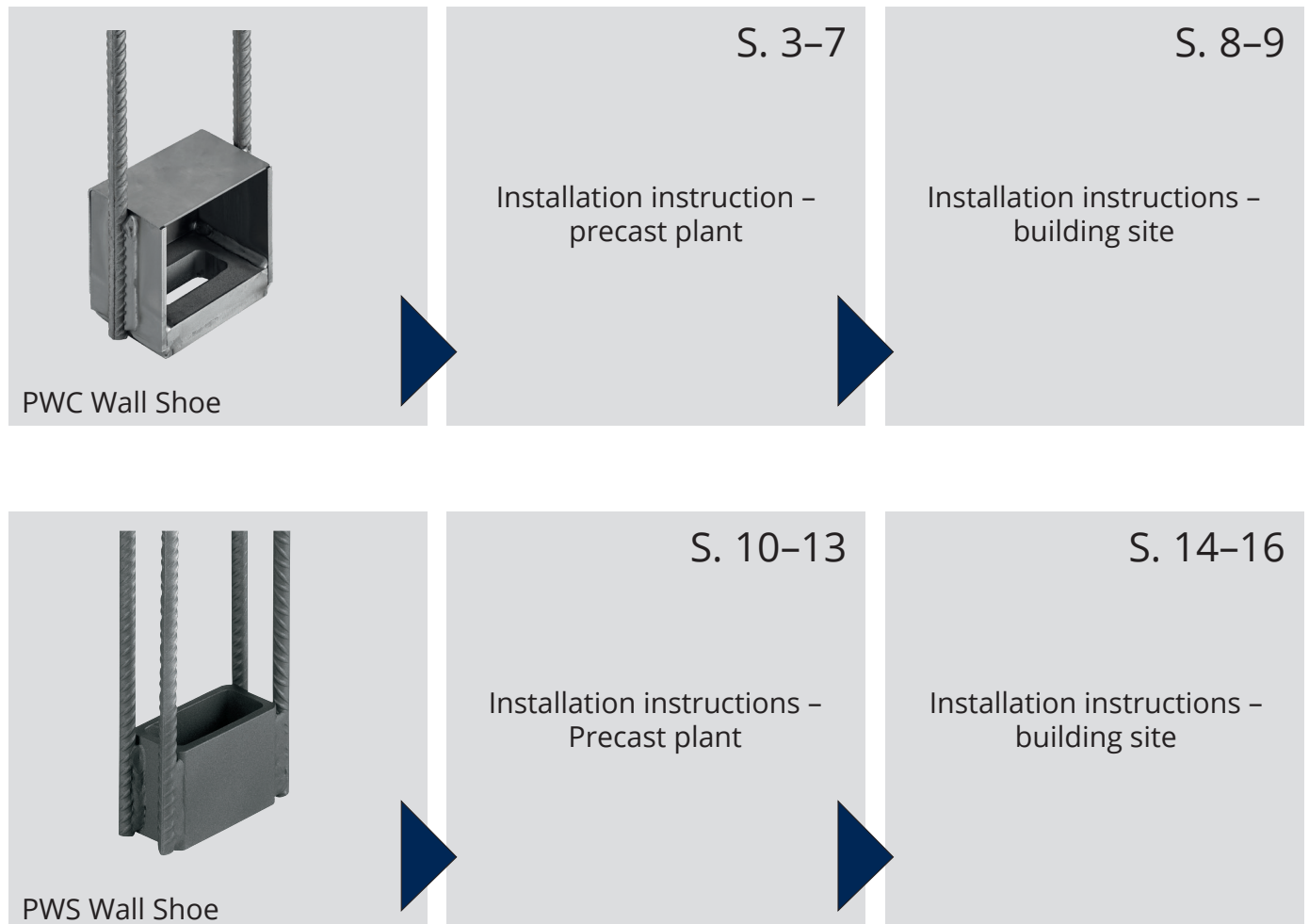

# PWC installation

## Installation instruction – precast plant:

### Positioning the wall shoes

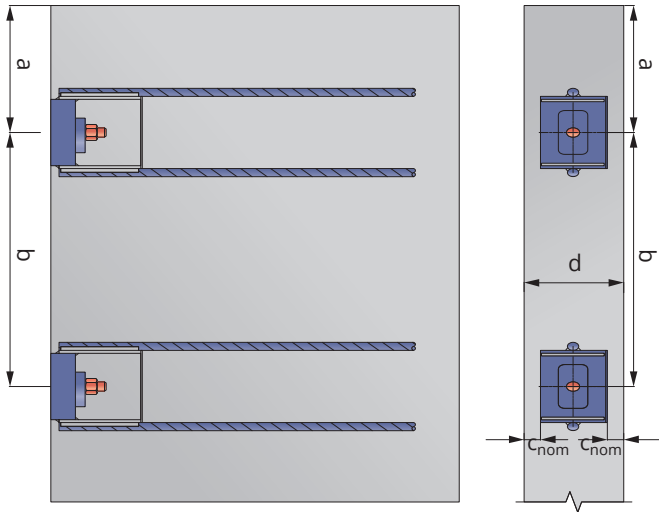

When installing the PFEIFER PWC Wall Shoe, the required concrete cover  $c_{nom}$  according to EN 1992-1-1 must be complied with for the edge distances and the minimum wall thickness.

The minimum wall thicknesses arise from the wall shoe width and the concrete cover per wall side to be determined during the planning.

Thanks to the arrangement of the slots in the base plate of the wall shoe, generous tolerances are possible. Inaccuracies can thus be compensated easily when installing in the precast plant and when adjusting on the building site.

#### Minimum distances and dimensions

The following edge and axis distances as well as the minimum wall thicknesses result from the wall shoe dimensions, the required additional reinforcement and the concrete cover.

Figure 1 + Figure 2

Wall shoe type	Edge distance a [mm]	Axis distance b [mm]	Minimum wall thicknesses d [mm]
PWC 16	220	440	$82 + 2 \times c_{nom}$
PWC 20	260	520	$92 + 2 \times c_{nom}$
PWC 24	360	720	$112 + 2 \times c_{nom}$
PWC 30	320	640	$122 + 2 \times c_{nom}$
PWC 36	380	760	$132 + 2 \times c_{nom}$
PWC 39	350	700	$147 + 2 \times c_{nom}$
PWC 30 HF	320	640	$132 + 2 \times c_{nom}$
PWC 35 HF	380	760	$152 + 2 \times c_{nom}$

Table 1: Distances and minimum wall thicknesses

# PWC – installation instruction for the precast plant

## Installation of the wall shoe

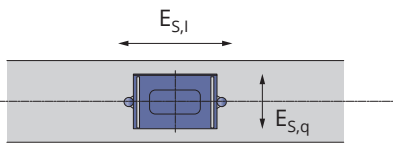

Figure 3: xxxxx

PFEIFER wall shoes are fixed as built-in parts to the front side of the formwork of the wall panels. The following tolerances must be adhered to when installing the wall shoes.

Wall shoe type	Wall shoe installation tolerance	
	Longitudinal direction $E_{S,l}$ [mm]	Transverse direction $E_{S,q}$ [mm]
PWC 16	± 5	± 2
PWC 20	± 5	± 2
PWC 24	± 5	± 3
PWC 30	± 5	± 3
PWC 36	± 5	± 3
PWC 39	± 5	± 3
PWC 30 HF	± 5	± 3
PWC 35 HF	± 5	± 3

Table 2

## Assembly of the foundation anchor

The following tolerances should also be adhered to when installing the PFEIFER Foundation Anchor.

Wall shoe type	Wall shoe installation tolerance		Bolt height $h_B$ [mm]
	Longitudinal direction $E_{A,l}$ [mm]	Transverse direction $E_{A,q}$ [mm]	
PWC 16	± 3	± 3	100
PWC 20	± 3	± 3	110
PWC 24	± 3	± 3	115
PWC 30	± 3	± 3	135
PWC 36	± 3	± 3	160
PWC 39	± 3	± 3	160
PWC 30F	± 3	± 3	155
PWC 35F	± 4	± 4	165

Table 3

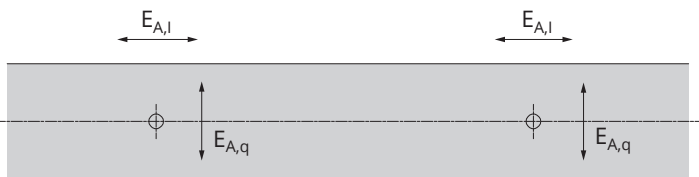
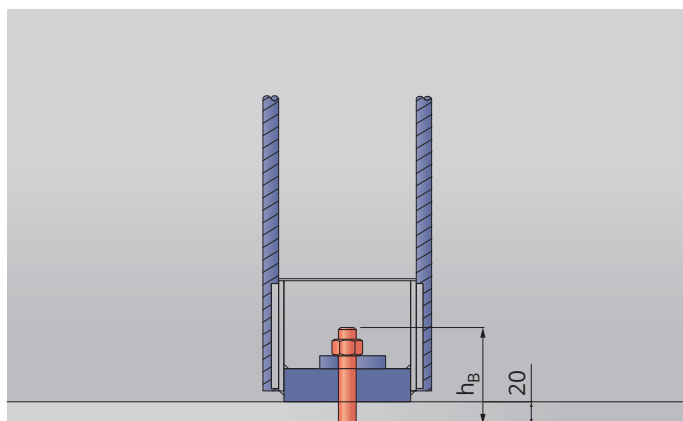

Figure 4



Subsequently grout the upper edge of the wall or foundation joint

Figure 5

# PWC – installation instruction for the precast plant

## Additional reinforcement

In addition to the wall shoes, provide a corresponding reinforcement layout in the components in order to transmit the loads from the wall into the wall shoe in a concentrated manner or, in the anchor area, to transmit them from the built-in component back into the wall.

## Connection reinforcement

Wall shoe type	Additional connection reinforcement	
	Longitudinal reinforcement [-]	Max. overlap length $l_0$ [cm]
PWC 16	2 Ø 14	52
PWC 20	2 Ø 16	90
PWC 24	2 Ø 20	100
PWC 30	2 Ø 25	124
PWC 36	2 Ø 25	180
PWC 39	2 Ø 28	188
PWC 30 HF	2 Ø 28	149
PWC 35 HF	2 Ø 32	186

**Table 4:** Additional connection reinforcement

The acting tensile forces must be relayed into the components and guided into the foundation by additional reinforcements and corresponding overlapping joints. The required longitudinal reinforcement is illustrated in the following table.

The connection reinforcement is to be led up to the top edge of the wall shoe box and is joined to the welded rebars of the wall shoe. The length of the welded bars is selected so that the overlap length is adhered to with maximum utilisation.

## Shear reinforcement at the overlapping joint

Wall shoe type	Additional shear reinforcement – closed stirrup	
	Quantity and diameter* [-]	Joint area $0,3 \times l_0$ [cm]
PWC 16	4 Ø 6	16
PWC 20	6 Ø 6	27
PWC 24	6 Ø 8	30
PWC 30	8 Ø 8	37
PWC 36	7 Ø 10	54
PWC 39	8 Ø 10	56
PWC 30F	6 Ø 10	45
PWC 35F	10 Ø 10	56

\* Quantity per joint area

**Table 5:** Additional shear reinforcement – closed stirrup

According to EN 1992-1-1, paragraph 8.7.4, shear reinforcement is to be provided in the overlap area in order to absorb shear forces. This shear reinforcement is to be installed in the form of closed stirrups and concentrated in the start or end area of the overlap length.

# PWC – installation instruction for the precast plant

## Stirrup

In addition, stirrups must be located in the area of the wall shoe box. Eccentric installation of the wall shoe can result in horizontal loads, which are absorbed by the stirrup.

Wall shoe type	Additional shear reinforcement – stirrup	
	Quantity and diameter**	Stirrup length $0,3 \times l_{BÜ}$
	[-]	[cm]
PWC 16	2 x 2 Ø 8	12,5
PWC 20	2 x 2 Ø 8	15,5
PWC 24	2 x 3 Ø 8	24,0
PWC 30	2 x 4 Ø 8	19,0
PWC 36	2 x 4 Ø 8	24,5
PWC 39	2 x 4 Ø 10	20,5
PWC 30 HF	2 x 4 Ø 10	19,0
PWC 35 HF	2 x 4 Ø 10	23,5

\* Quantity per wall shoe side

**Table 6:** Additional shear reinforcement – stirrup

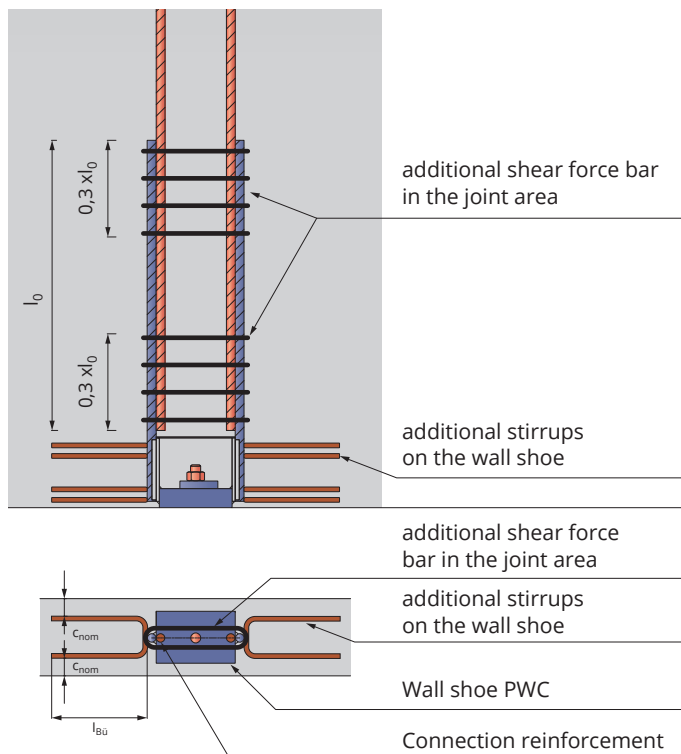

**Figure 6:** Reinforcement arrangement PWC 16H

## Assignment of the wall shoe to the washer and foundation anchor:

Wall Shoe Typ	Washer Typ	Foundation anchors Typ PGS
PWC 16	UP 16	G1/G1-K/H2 16
PWC 20	UP 20	G1/G1-K/H2 20
PWC 24	UP 24	G1/G1-K/H2 24
PWC 30	UP 30	G1/G1-K/H2 30
PWC 36	UP 36	G1/G1-K/H2 36
PWC 39	UP 39	G1/G1-K/H2 39
PWC 30 HF	UP 30-HF	G2/H2 30
PWC 36 HF	UP 36-HF	G2/H2 36

**Table 7**

# PWC assembly instructions – building site

## Identification

The wall shoes are provided with an identification sticker on the housing. This provides information about the size or type of the wall shoe, the parts or reference number and the address of the manufacturer with all relevant data.



**Figure 7:** Marking wall shoe

The following steps are required to assemble the wall element:

- Remove the nuts and washers of the foundation anchor
- Create the appropriate joint with the help of shim plates
- Position the wall element on the shim plates
- Check the correct position of the wall element
- Screw on the nuts and washers and tighten firmly.
- Grout the assembly recess and the wall joint
- Connection is finished after curing of the joint filling mortar

## Wall assembly

When adjusting the wall on the building site, the following tolerance specifications allow the exact alignment of the components. The dimensions already take into account the corresponding installation tolerances for wall shoe and foundation anchor.

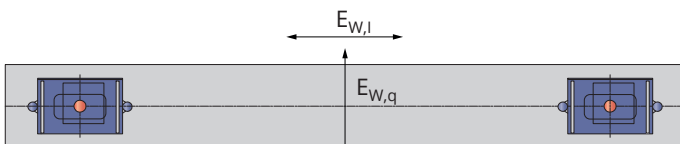

**Figure 8**

Wall shoe type	Wall shoe type tolerance wall connection	
	Longitudinal direction $E_{w,l}$ [mm]	Transverse direction $E_{w,q}$ [mm]
PWC 16	± 20	± 5
PWC 20	± 20	± 5
PWC 24	± 20	± 5
PWC 30	± 20	± 5
PWC 36	± 20	± 5
PWC 39	± 20	± 5
PWC 30 HF	± 20	± 5
PWC 35 HF	± 20	± 5

**Table 8:** Assembly tolerances when adjusting

## Installation instruction – precast plant

### Minimum thicknesses of the wall components

The minimum wall thicknesses for wall components with wall shoes specified in Table 10 result from the wall shoe dimensions, the surface reinforcement and the concrete cover.

**Table 9:** Minimum wall thicknesses

PWS 120	PWS 200	PWS 330	PWS 400	PWS 650	PWS 900
160 mm	160 mm	180 mm	200 mm	210 mm	210 mm

### Edge and axis distances

The edge and axis distances are to be taken into account to the extent that the required concrete cover  $c_{nom}$  according to EN 1992-1-1 is complied with. This protects the built-in parts against corrosion and serves to transmit the acting forces.

In addition, take care that the upright bars of the planned wall shoes meet the requirements according to EN 1992-1-1 for the minimum distances ("transverse distance between rebars") in case of joints without a longitudinal offset of  $\geq 2\phi_s/\geq 20$  and of  $e \geq \phi_s/\geq 20$  mm with parallel running rebars.

### Installation tolerances

PFEIFER wall shoes are fixed as built-in parts to the front side of the formwork of the wall panels. The installation tolerances depend on the size of the selected wall shoe and the outer diameter of the anchoring bolt. From the respective combination, a sufficiently large tolerance range according to Table 11/ Fig. 10 results so that even larger inaccuracies can be bridged on the building site individually and without additional time expenditure.

**Table 10:** Horizontal tolerances

PWS 120	PAP 16	PAP 20	PAP 24
längs ± L	± 40 mm	± 35 mm	± 30 mm
quer ± Q	± 14 mm	± 12 mm	± 10 mm
PWS 200	PAP 24	PAP 30	
längs ± L	± 30 mm	± 20 mm	
quer ± Q	± 10 mm	± 17 mm	
PWS 330	PAP 30	PAP 36	
längs ± L	± 30 mm	± 20 mm	
quer ± Q	± 10 mm	± 17 mm	
PWS 400	PAP 36	PAP 42	
längs ± L	± 20 mm	± 15 mm	
quer ± Q	± 12 mm	± 19 mm	
PWS 650	PAP 42	PAP 48	
längs ± L	± 35 mm	± 25 mm	
quer ± Q	± 14 mm	± 11 mm	
PWS 900	PAP 48	PAP 56	
längs ± L	± 25 mm	± 25 mm	
quer ± Q	± 11 mm	± 17 mm	

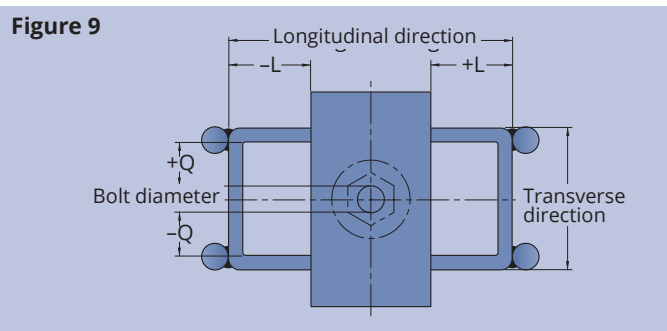



## Installation instruction – precast plant

### Assembly recess

The necessary assembly recess in the wall can be manufactured with the aid of a foam polystyrene recessing block (fig. 2). Select the dimensions of the block so that, on the one hand, the concrete cover of at least 1.5 cm according to EN 1992-1-1 is ensured and, on the other, the anchor plate has sufficient clearance to the rear. The optimum foam polystyrene recessing block dimensions for the axial installation of a wall shoe in a 20 cm thick wall are specified in Table 11:

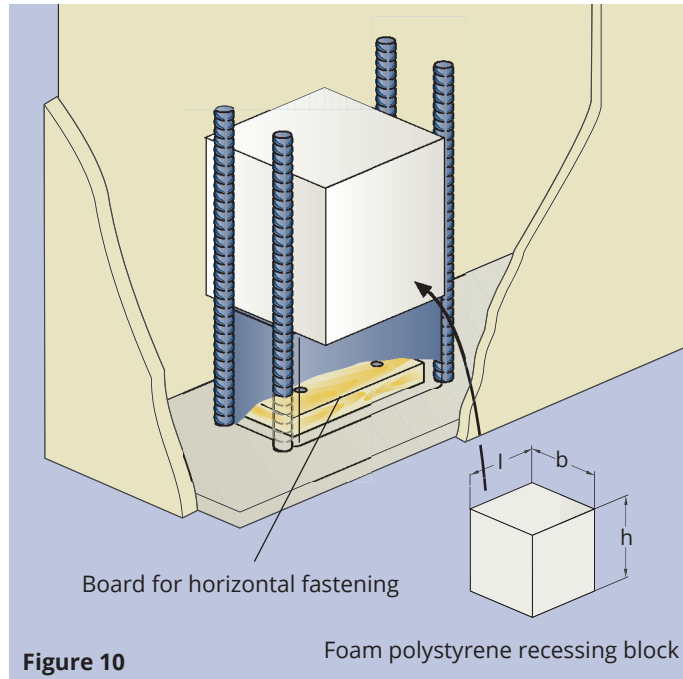

Table 11 shows the optimal styrofoam recess former dimensions for the axial installation of a wall shoe in a 20 cm thick wall:

Typ	b [mm]	h [mm]	l [mm]
PWS 120	170	110	120
PWS 200	170	130	120
PWS 330	170	150	140
PWS 400	170	180	140
PWS 650	170	180	180
PWS 900	170	180	180

**Table 11:** Recessing block dimensions

The recessing block is not included in the scope of delivery.

## Installation instruction – precast plant

### Reinforcement layout

Take care that the forces occurring are transmitted into the wall shoe by overlapping joints or a suitable reinforcement layout. The necessary reinforcement must be proven for each individual case and inserted on site. Fig. 11 shows an example of the relaying of forces within wall panels situated above one another. The shear reinforcement (stirrups) required to absorb the deviation forces and splitting tensile forces occurring in the anchoring area is to be proven with a type-static calculation test according to EN 1992-1-1 and installed (figs. 12 & 13). Furthermore, take the reinforcement guidelines as well as the specifications for the minimum concrete cover according to EN 1992-1-1 into account.

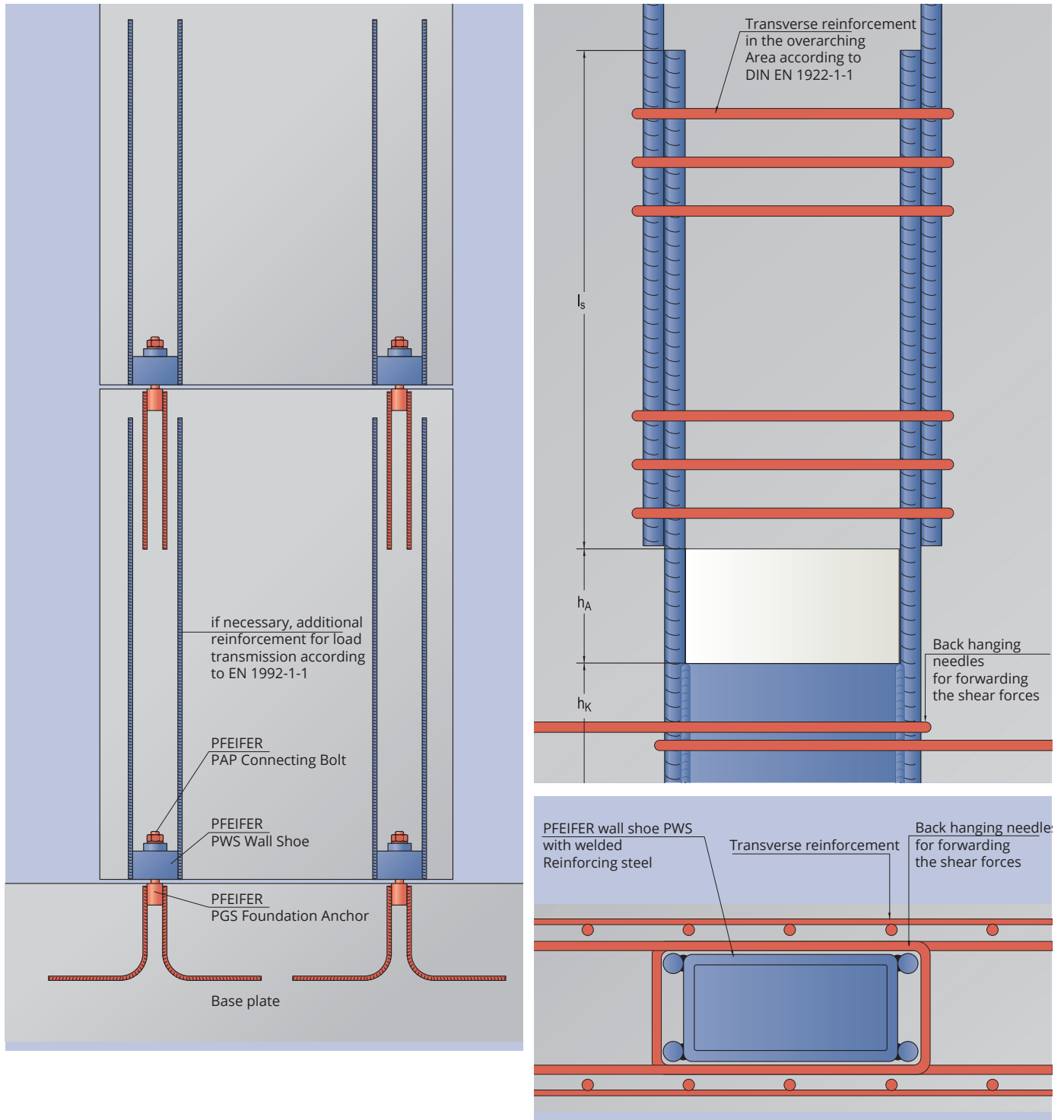

## Installation instructions – building site

The PWS Wall Shoes are provided with a marking band on the welded rebar. This provides information about the size or type of the wall shoe, the parts or reference number and the address of the manufacturer with all relevant data.



**Figure 14:** Identification of the wall shoe PWS

### Installation of the wall elements

Shortly before the installation of the wall elements, the recess discs or bolts inserted for protection are removed from the foundation anchor sleeve. The PFEIFER Anchor Bolt is then screwed in. The screw-in depth in the foundation anchor is 2 x the thread diameter. With the help of shims, the precast wall elements are then positioned and aligned in their final position. After inserting the anchor plate, the nut can be tightened.

To reduce the deformations, the screwed connections should generally be pre-tensioned with 50% of the tightening values according to DIN 18800, Part 7. If necessary, lower or higher pre-tensioning forces can be planned by the engineer for individual applications.

## Grouting

### Grouting the recess

The additional grouting of the cavity in the wall shoe body with a free-flowing and low-shrinkage grouting concrete ensures the transmission of shear forces longitudinally and transversely to the joint. The high-strength, very free-flowing, self-compacting grouting mortar is to be used.

The grouting process must be carried out via the filling funnel as far as possible without interruption.

A reusable cover plate with filling funnel is available for the simple, fast and clean filling of the assembly recess. Lash the cover plate to the threaded bolt using a cable tie. After the hardening of the grout, simply cut the cable tie and re-use the sheet (figs. 15 & 16).

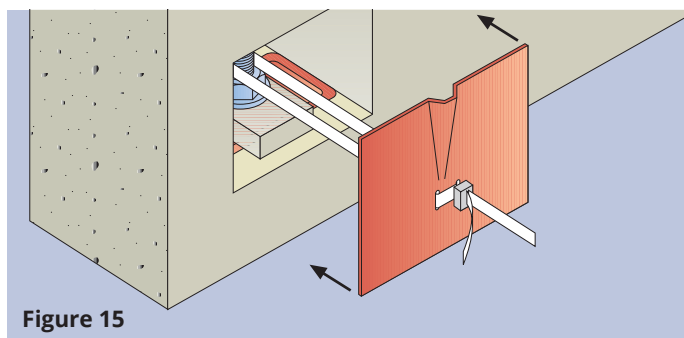

**Figure 15**

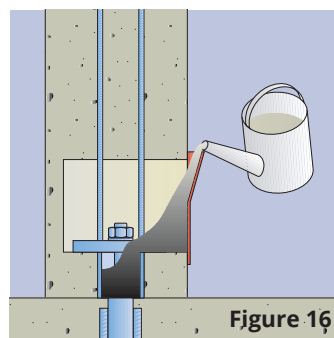

**Figure 16**

## International

### Sales

+49 (0) 83 31-937-231

### Technical Support

+49 (0) 83 31-937-345

[export-bt@pfeifer.de](mailto:export-bt@pfeifer.de)

[www.pfeifer.info/concrete-inserts](http://www.pfeifer.info/concrete-inserts)

**PFEIFER**