

Impressive application safety ...

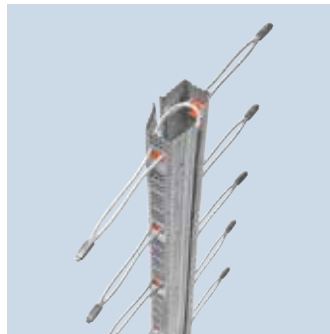
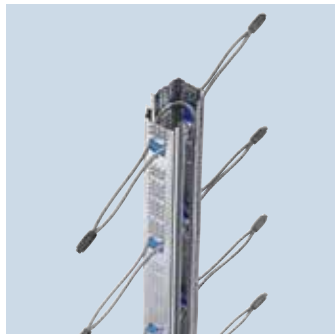

03/2019

Approved **PFEIFER-VS®**  
rail systems<sup>3D</sup>

**PFEIFER  
SEIL- UND HEBETECHNIK  
GMBH**

DR.-KARL-LENZ-STRASSE 66  
D-87700 MEMMINGEN

PHONE Technical +49 83 31-937-345  
Support +49 83 31-937-231  
Sales +49 83 31-937-342

FAX +49 83 31-937-342  
E-MAIL [export-bt@pfeifer.de](mailto:export-bt@pfeifer.de)  
INTERNET [www.pfeifer.info](http://www.pfeifer.info)

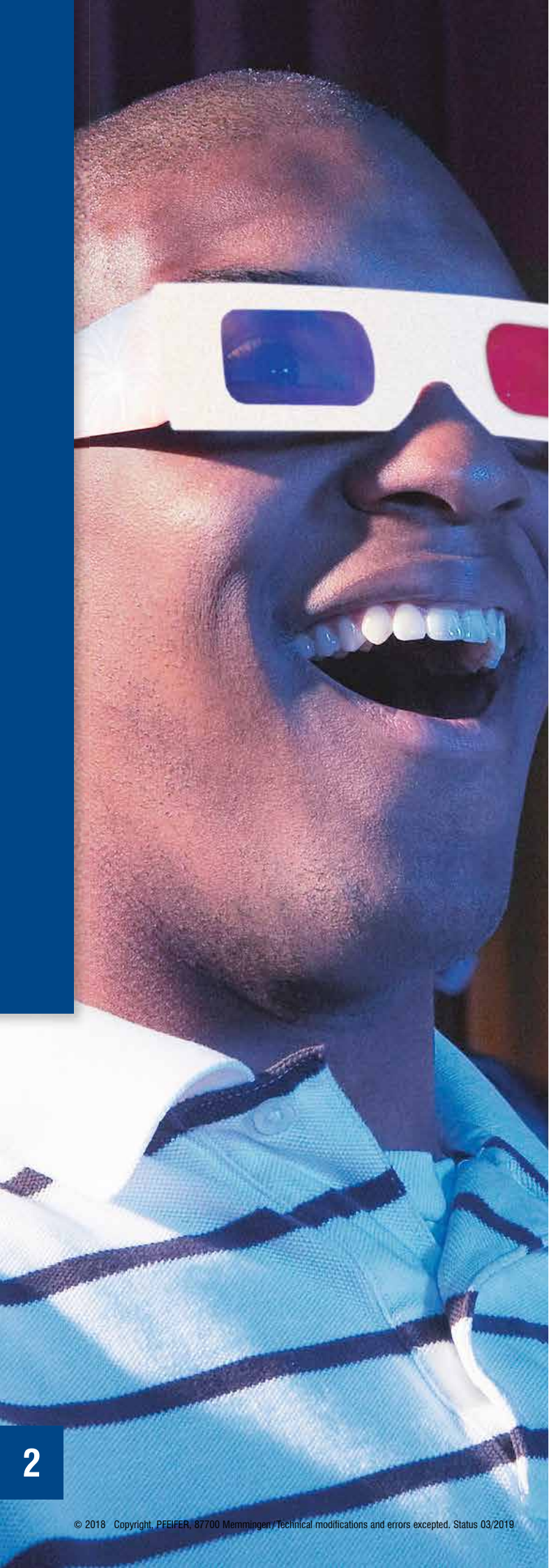

## Impressive application safety and performance – PFEIFER-VS® rail systems<sup>3D</sup>

+ Transverse forces  $V_{Rd II}$   
in parallel direction  
technically approved

+ Solid, static shear  
force model

+ Particularly high trans-  
mission of shear forces

+ Tested and approved for  
wall thicknesses from  
140 mm

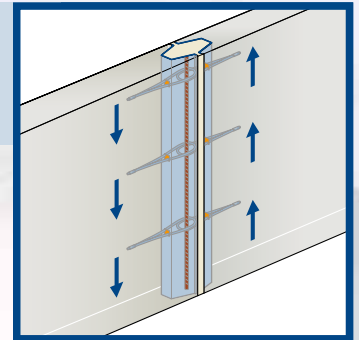

+ Tensile stress  $Z_{Rd}$   
possible to plan

+ Approved by the  
building authorities

+ No requirement for  
ring beams or tie rods

+ Can sustain constraining  
forces

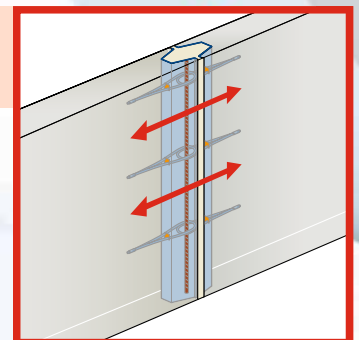



## Your VS® System advantages

- National technical approval
- Symmetric rail profiles – installation NOT tied to one direction
- Optimised joint geometries – less mortar needed
- 3D interaction model permits overlapping in all load directions
- No protruding cross-sections on the rails
- Unmistakeable blue clip mark
- No additional static measures needed
- Optimum profile for optimum connection
- Solve all joining requirements with a few product variants
- Flexible use of three mortar suppliers (VS® ISI)
- Possible to fill joints with grout and joint filling mortar
- Maximum execution safety
- No additional formwork measures required – profiles form the whole joint profile
- Low error potential (no formwork)
- Can be used in fire protection walls
- Dimensioning software

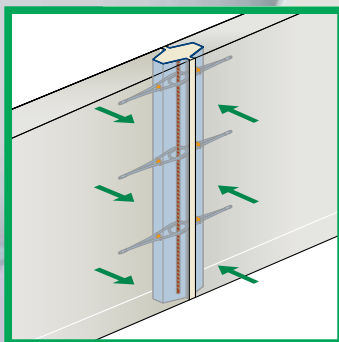
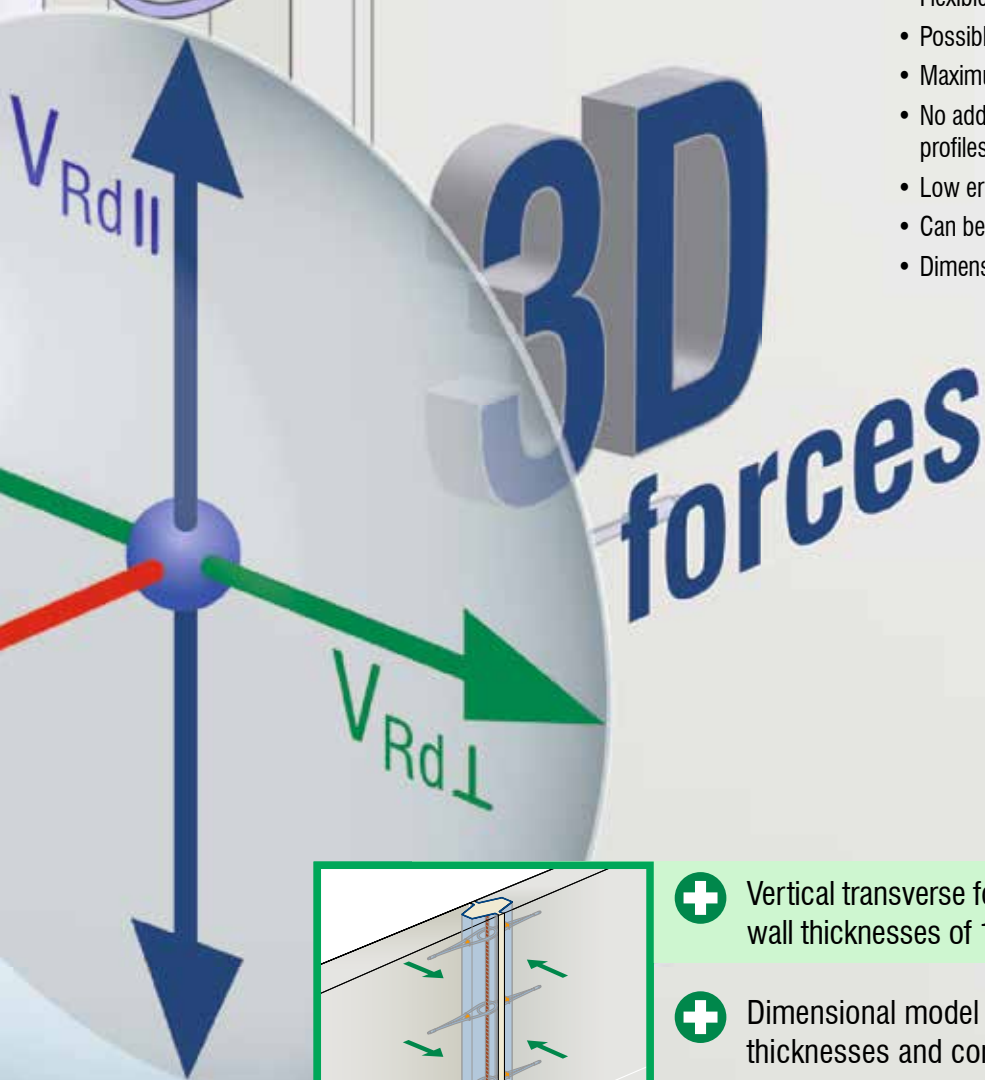

Vertical transverse force  $V_{Rd\perp}$  tolerated from wall thicknesses of 140 mm



Dimensional model includes wall thicknesses and concrete strength



Force transfer even in case of fire

# PFEIFER-VS® ISI System<sup>3D</sup> – forget execution errors – ISI is always right!

## + Safety

- Maximum tolerances
- Loop position always fits
- No reduction due to large loop spacings

- **One design resistance for all mortars**

**NEW**

← Look for the blue mark and forget the arrow!

## + Symmetry

- Non-directional installation
- Loop spacings always fit
- Practical

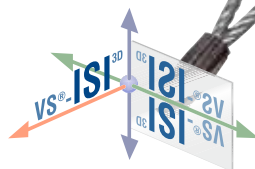

## + Efficiency

- Minimum mortar use
- Highest carrying capacities

## + Force transmission

- Design resistances in every direction

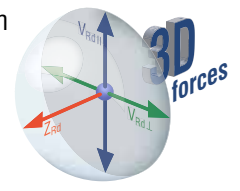

## + Innovation

- Practice-orientated grouting system
- Dimensioning software



## + Quality

- Construction-orientated profiles with no loose plastic elements
- National technical approval

# PFEIFER VS® ISI-System<sup>3D</sup>



**PFEIFER**

Reinforcement technology

VS® ISI System<sup>3D</sup>

The PFEIFER VS® ISI System<sup>3D</sup> creates load bearing connections between precast wall panels and columns and wall-wall connections. Parallel and vertical transverse forces with respect to the joint and tensile strength are regulated by the national technical approval authorities.

Both grouting materials and joint filling mortar with plastic/thixotropic properties are available as joint filling materials in accordance with the approval.

### Advantages:

- Practical solution for connecting precast parts
- Maximum process reliability
- Can be installed in any direction
- Maximum vertical tolerance
- Same design resistance for all grouts and filling mortars

### Materials:

- Rail: Galvanised sheet steel  
 Steel wire rope: Highly tensile, galvanised  
 Cover: Tape

### Approved filling

#### material manufacturer:

- PAGEL®  
Spezialbeton GmbH & Co. KG
- P & T  
Technische Mörtel GmbH & Co. KG
- BETEC®

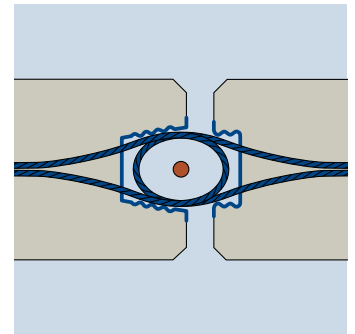
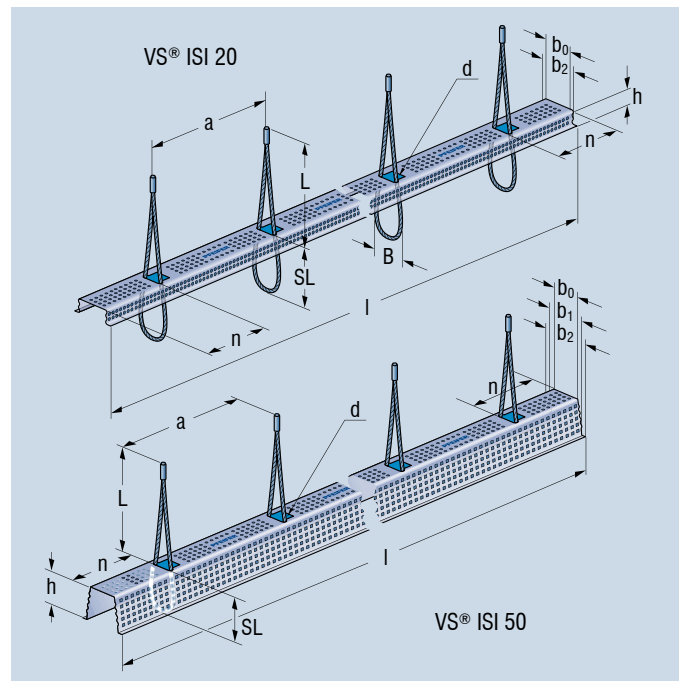

Order no.	Type	Dimensions										Number of loops	Packing unit [ea.]	Weight approx. [kg/ea.]	
		b <sub>0</sub> [mm]	b <sub>1</sub> [mm]	b <sub>2</sub> [mm]	h [mm]	l [mm]	SL [mm]	L [mm]	a [mm]	n [mm]	B [mm]				d [mm]
05.030.236.20	VS® ISI 20	50	–	70	20	1180	80	227	236	118	60	3	5	100	1.32
05.027.236.50	VS® ISI 50	50	65	80	50	1180	80	227	236	118	60	3	5	60	1.66
05.030.720	Replacement tape for cut-to-length rails		50 m long roll, silver-grey, 72 mm wide												
05.027.960	Replacement tape for cut-to-length rails		50 m long roll, silver-grey, 96 mm wide												



The grouting channel can be economically extended without loops using VS®-ISI empty profiles.

These can be cut to size individually using an angle grinder. Additional formwork is then no longer necessary.

Ref.No. (Reference number): 05.030.000 (Typ VS®-20/000)  
 05.027.000 (Typ VS®-50/000)

# PFEIFER VS<sup>®</sup> BZ System<sup>3D</sup> – the perfect symmetrical Wall-Wall connection!



## Symmetry

- Non-directional installation
- Loop spacings always fit
- Practical



## Innovation

- Practice orientated grouting system
- Dimensioning software



## Efficiency

- Minimum mortar use
- Highest carrying capacities



## Force transmission

- Design resistances in every direction

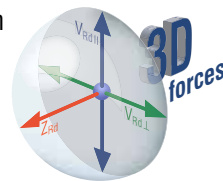

## Quality

- Construction-orientated profiles with no loose plastic elements
- National technical approval

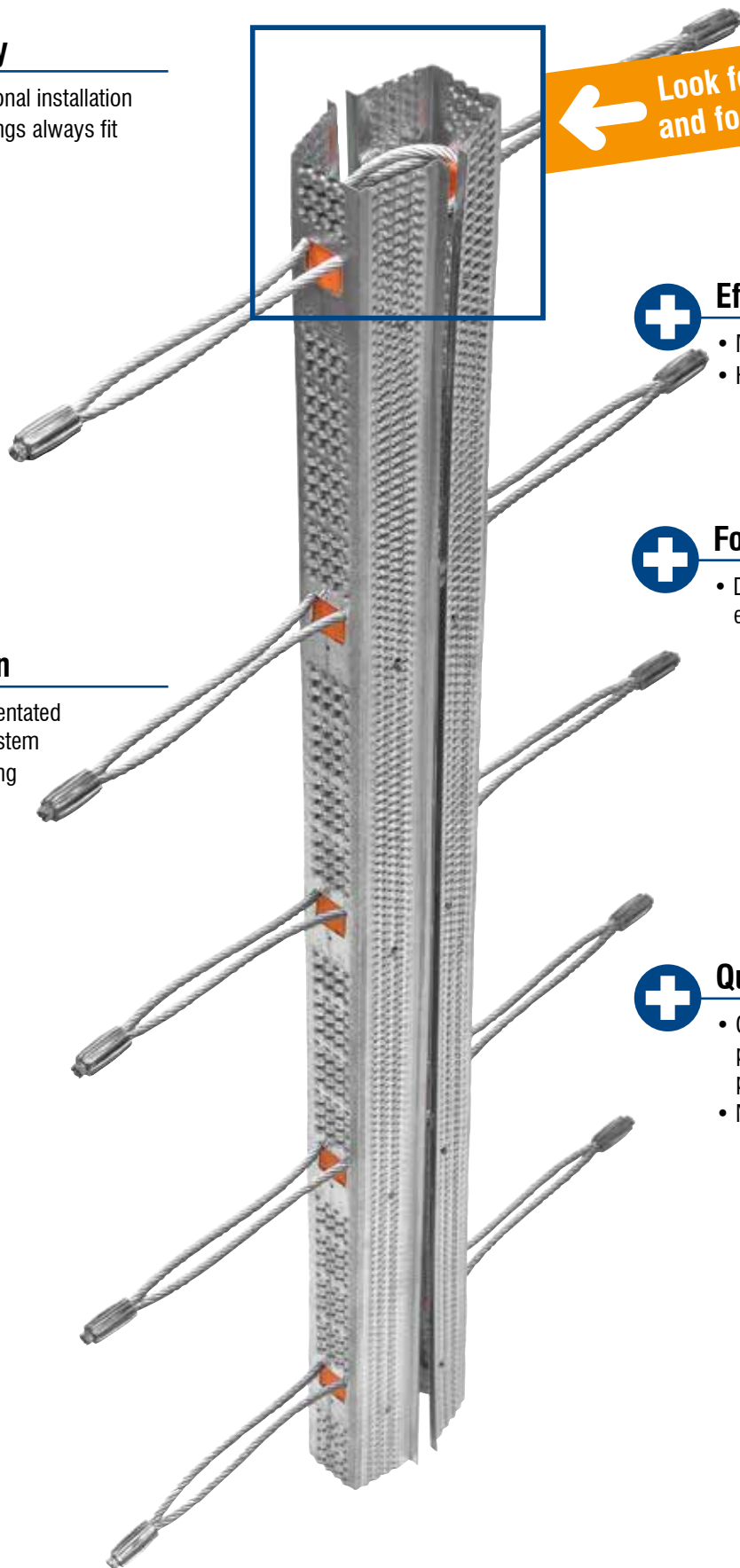

# PFEIFER VS® BZ system<sup>3D</sup>



**PFEIFER**

Reinforcement system  
VS® BZ System<sup>3D</sup>

The PFEIFER-VS®-rail BZ is used for the load bearing connection mainly of precast wall elements. Transmission of tensile and shear forces parallel and vertical are regulated by the building authorities.

The user has both a grout material and a joint filling mortar with plastic/thixotropic properties in accordance with approval at its disposal.

**Advantages:**

- Practical solution for connecting precast parts
- Maximum process reliability
- Can be installed in any direction
- Maximum vertical tolerance

**Materials:**

- Rail: Galvanised sheet steel  
 Steel wire rope: Highly tensile, galvanised  
 Cover: Tape

**Approved filling**

**material manufacturer:**

- PAGEL®  
 Spezialbeton GmbH & Co. KG

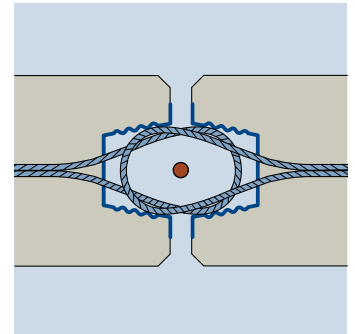
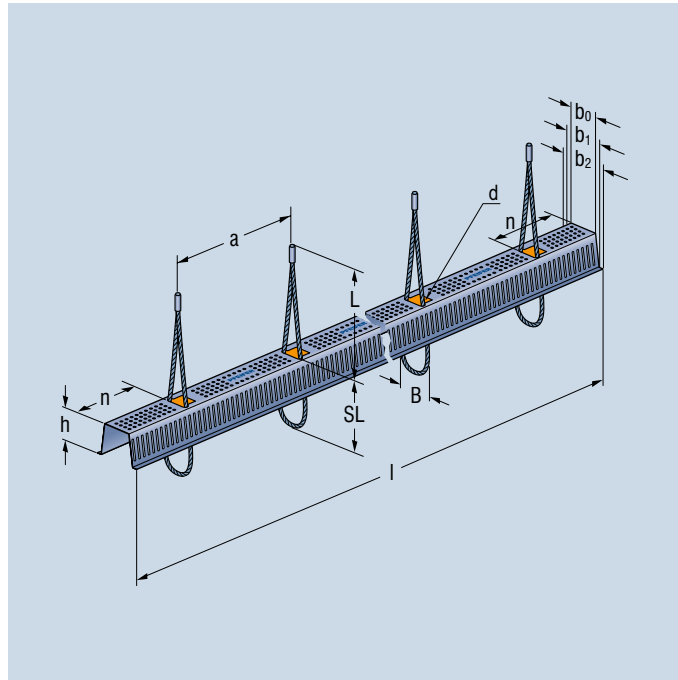

Order no.	Type	Dimensions											No. of loops	Packing unit [each]	Weight approx. [kg/ea.]	
		b <sub>0</sub> [mm]	b <sub>1</sub> [mm]	b <sub>2</sub> [mm]	h [mm]	l [mm]	SL [mm]	L [mm]	a [mm]	n [mm]	B [mm]	d [mm]				
05.027.236.01	VS®-BZ-50	50	64	80	50	1180	100	212	236	118	60	3	5	60	1.66	
05.027.960	Replacement tape for cut-to-length rails					50 m roll, silver-grey, 96 mm wide										



Length adaptations of the casting channel can be realised cost efficiently with empty VS® rail profiles. These can be adapted individually by means of disc cutter. Additional formwork is then no longer necessary.

Order number: 05.027.000 (type VS® 50/000)

## System description

The PFEIFER VS®-ISI System<sup>3D</sup> und VS®-BZ System<sup>3D</sup> (Figure 1) is intended for the connection of precast steel reinforced concrete walls to each other or steel reinforced concrete walls to columns. According to building authority approvals, the user has a choice of different materials with appropriate properties for filling the joints.

From component thicknesses of 140 mm the connections are approved for mainly static **impacts from all three directions** (<sup>3D</sup>) (Figs. 2 and 3). In the case of a right-angle joint (Figs. 5 and 6), the thickness of the jointed wall can be reduced to 100 mm. The PFEIFER VS® ISI System<sup>3D</sup> can be used according to Figure 4 – 7. The PFEIFER VS® BZ System<sup>3D</sup> can be used according to figure 4.

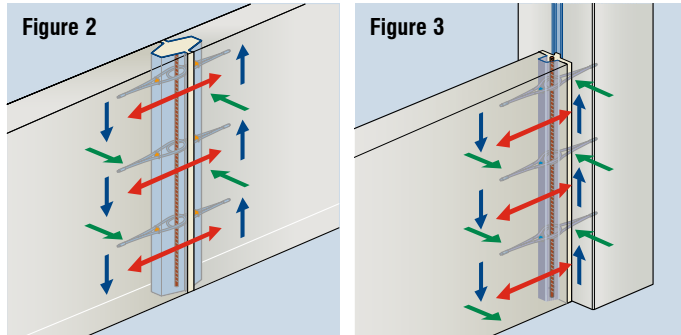

Admissible load direction – tensile forces and transversal shear force parallel and vertical to the joint.

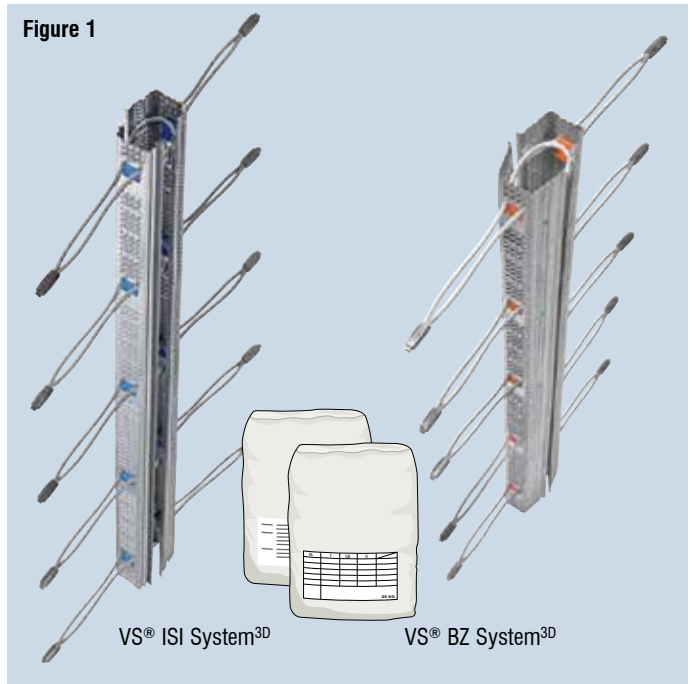

## Intended use

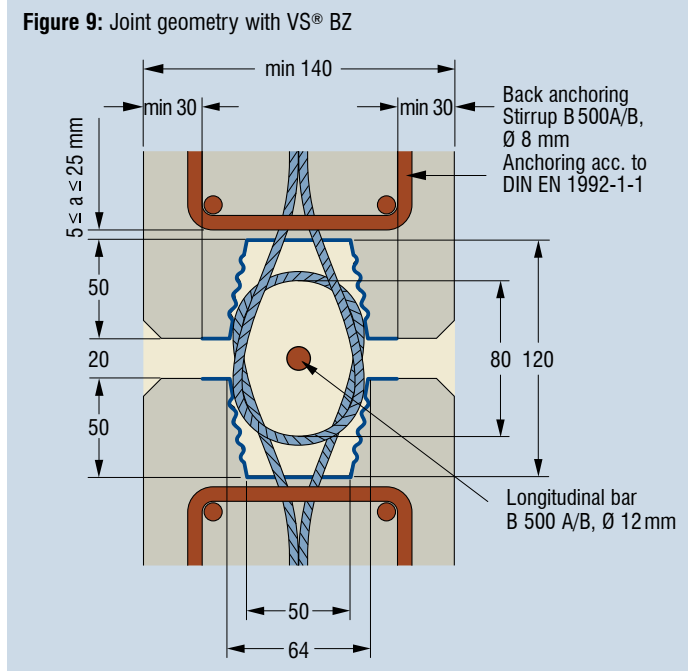
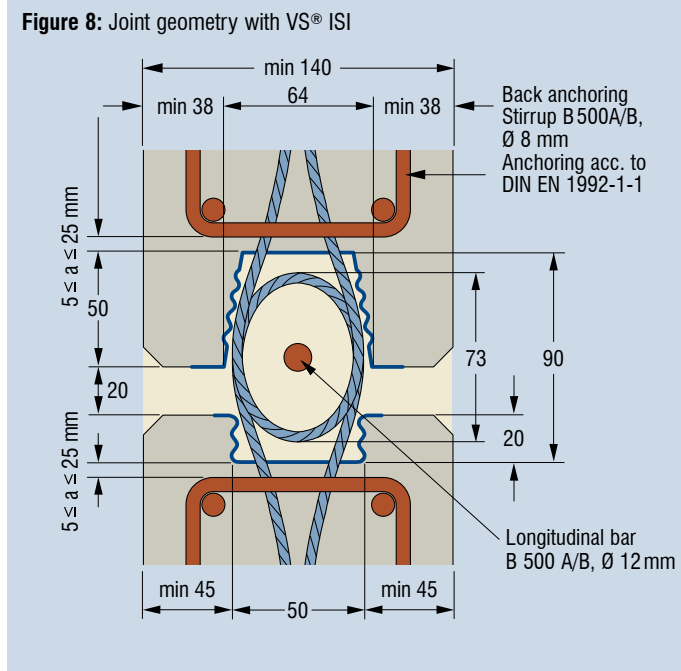
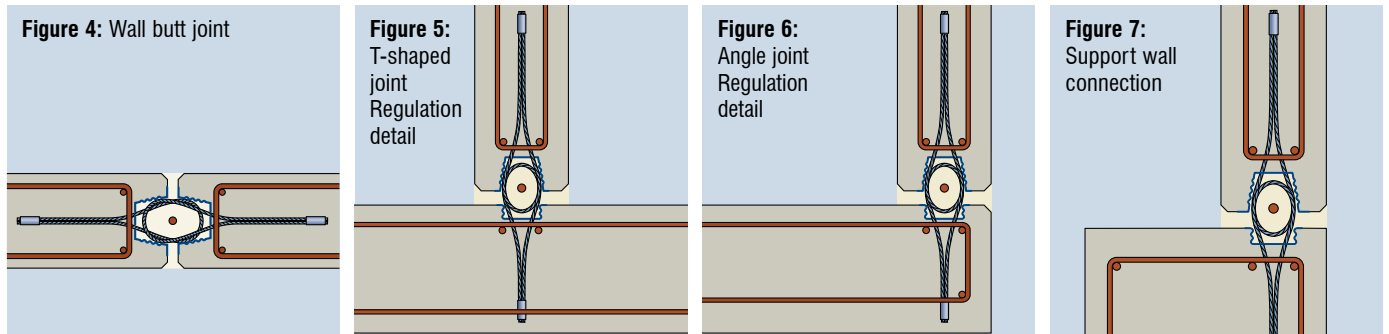



## Dimensioning

The concrete precast parts of steel-reinforced concrete to be joined must be dimensioned by the responsible designer according to DIN EN 1992-1-1 in a minimum concrete quality of C30/37. Connections made with the VS® ISI System<sup>3D</sup>/BZ 50 System<sup>3D</sup> are seen as reinforced joints with design resistances for tensile and transversal shear forces. Appropriate design resistances are listed in Tables 1/2. When dimensioning the connection, verification must then be conducted separately for each load direction. It is

**Table 1 – design resistances VS® ISI System<sup>3D</sup>** NEW

Wall thickness [cm]	Design resistance Vertical transverse force				Design resistance Transverse force, parallel $V_{Rd, II}$ [kN/m]	Design resistance Tensile force $Z_{Rd}$ [kN/m]
	$V_{Rd, \perp}$ [kN/m]					
	C 30/37	C 35/45	C 40/50	C 45/55		
14	9.7	11.1	11.9	12.6	60	36 28
16	12.7	14.4	15.5	16.5	60	36 28
18	15.9	18.1	19.4	20.7	60	36 28
20	19.3	21.9	23.5	25.1	60	36 28
22	22.8	26.0	27.9	29.7	60	36 28
24	26.6	30.3	32.5	34.6	60	36 28
26	30.5	34.8	37.3	37.5	60	36 28
28	34.6	37.5	37.5	37.5	60	36 28
≥ 30	37.5	37.5	37.5	37.5	60	36 28

blue dimensioning values when using grouting material  
red dimensioning values when using plastic/thixotropic material (possible materials according to P. 13)

important here to ensure that tensile forces acting from the outside and the resultant tensile forces from the acting transverse forces are taken into account. If no external tensile force should be applied, a simplified analysis via an interaction diagram in accordance with the approval can be used. The acting expansion forces then need to be validated.

Crack widths due to outdoor constraint stresses should be limited (DIN EN 1992-1-1).

**Table 2 – design resistances VS® BZ System<sup>3D</sup>**

Wall thickness [cm]	Design resistance Vertical transverse force				Design resistance Transverse force, parallel $V_{Rd, II}$ [kN/m]	Design resistance Tensile force $Z_{Rd}$ [kN/m]
	$V_{Rd, \perp}$ [kN/m]					
	C 30/37	C 35/45	C 40/50	C 45/55		
14	9.7 9.7	11.1 11.1	11.9 11.9	12.6 12.6	60	55 36
16	12.7 12.7	14.4 14.4	15.5 15.5	16.5 16.5	60	55 36
18	15.9 15.9	18.1 18.1	19.4 19.4	20.7 20.7	60	55 36
20	19.3 19.3	21.9 21.9	23.5 23.5	25.1 25.1	60	55 36
22	22.8 22.8	26 26	27.9 27.9	29.7 29.7	60	55 36
24	26.6 26.6	30.3 30.3	32.5 32.5	34.6 34.6	60	55 36
26	30.5 30.5	34.8 34.8	37.3 37.3	39.7 39.7	60	55 36
28	34.6 34.6	39.4 39.4	42.3 42.3	45.1 43.2	60	55 36
≥ 30	38.8 38.8	44.2 43.2	47.4 43.2	48 43.2	60	55 36

blue Dimensioning values when using VS® PAGEL® Grout  
red Dimensioning values when using VS® P PAGEL® Casting Mortar

## Verification procedures

### Transverse force parallel to the joint

The design resistance of the shearing force parallel to joint  $V_{Rd, II}$  according to Table 1 can be used as the limit state for the carrying capacity of the shearing force parallel to the joint reinforced with the VS® ISI System<sup>3D</sup>/BZ 50 System<sup>3D</sup>.

$$\frac{V_{Ed, II}}{V_{Rd, II}} \leq 1,0$$

$V_{Ed, II}$  [kN/m]: transverse force acting parallel per meter of joint length  
 $V_{Rd, II}$  [kN/m]: design resistance of transverse force parallel to joint per meter

### Transverse force vertical to the joint

For transverses force vertical to the joint reinforced with the VS® ISI/BZ System<sup>3D</sup>, the design resistance  $V_{Rd, \perp}$  may be applied for the limit condition of the load-bearing capacity, depending on the component thickness and the strength category of the concrete precast element acc. to Table 1.

$$\frac{V_{Ed, \perp}}{V_{Rd, \perp}} \leq 1,0$$

$V_{Ed, \perp}$  [kN/m]: transverse force acting vertically per meter of joint length  
 $V_{Rd, \perp}$  [kN/m]: design resistance of transverse force vertical to the joint per meter



4 rope loops can be used per meter.  
VS®-ISI:  $Z_{Rd}$  of 9 kN/7kN applies per separate loop (Please observe the notes on joint materials in the dimensioning table 1).  
VS®-BZ:  $Z_{Rd}$  of 9 kN applies per separate loop (Please observe the notes on joint materials in the dimensioning table 2).

Expansion forces vertical to the joint resulting from stresses. These tensile forces can either be absorbed by the VS® rope loops or appropriately arranged through additional reinforcement or by other constructive actions and verified. The verification options of the tensile forces are illustrated in the following.

### Combined parallel and vertical transverse forces

In the case of simultaneous influence of transverse forces acting vertical and parallel to the joint, the interaction of the transverse forces must be verified using the interaction relationship illustrated in the diagrams (Figs. 10/11).

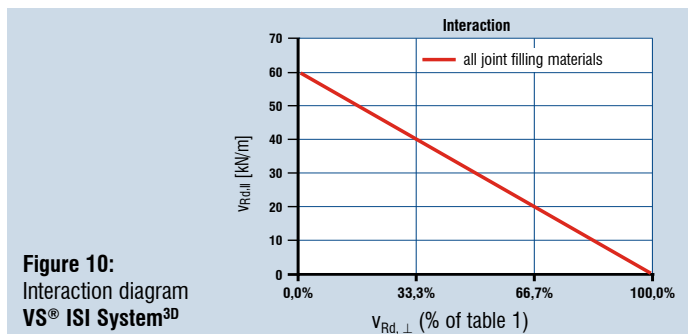

**Figure 10:**  
Interaction diagram  
VS® ISI System<sup>3D</sup>

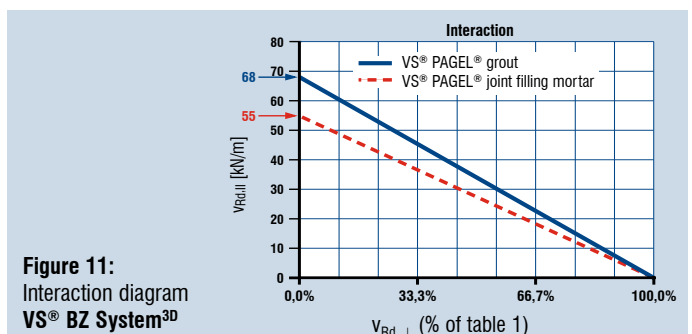

**Figure 11:**  
Interaction diagram  
VS® BZ System<sup>3D</sup>

## Tensile forces on the VS® loops

Separate tensile force components that act in the direction of the rope loop (Table 3a and 3b) result from the different loading directions. The sum of these separate components and any possible "external" tensile force that may be acting (total tensile force) is verified on the basis of tensile force resistance  $Z_{Rd}$  of the VS® ISI/BZ 50 System<sup>3D</sup> rail systems acc. to Table 1/2.

**Table 3a – tensile components ISI**

Stresses from	Parallel transverse force $V_{Ed,II}$ <b>NEW</b>	Vertical transverse force $V_{Ed,\perp}$	"External" tensile force
ISI Tensile force component	$Z_{Ed,VI} = 0,5 \cdot V_{Ed,II}$	$Z_{Ed,VI} = 0,25 \cdot V_{Ed,\perp}$	$Z_{Ed,N}$

**Table 3b – tensile components BZ**

Stresses from	Parallel transverse force $V_{Ed,II}$	Vertical transverse force $V_{Ed,\perp}$	"External" tensile force
BZ Tensile force component	$Z_{Ed,VII} = 0,6 \cdot V_{Ed,II}$	$Z_{Ed,VII} = 0,25 \cdot V_{Ed,\perp}$	$Z_{Ed,N}$

Verification of total tensile force:

$$Z_{Rd} = n \cdot Z_{Rd}$$

$$Z_{Rd} \geq Z_{Ed,VI} + Z_{Ed,VII} + Z_{Ed,N}$$

- $Z_{Rd}$  [kN/loop] : Design resistance per loop
- $Z_{Rd}$  [kN/m] : Design resistance of tensile force per meter of joint
- $Z_{Ed,N}$  [kN/m] : "External" tensile force acting per meter of joint
- $Z_{Ed,VI}$  [kN/m] : Expansion force from parallel transverse force per meter of joint
- $Z_{Ed,VII}$  [kN/m] : Expansion force from vertical transverse force per meter of joint

## Special case: tensile forces without consideration of the rope loops

The VS® rope loops are not used for transferring and imparting tensile forces, rather the sum of tensile forces  $Z_{Ed}$  must be assigned suitable tensioning members or other constructive measures. These can be tensioning members (e.g. ring beams) or other constructive measures (clamped columns, friction forces in fully erect wall elements, etc.). The tensile forces resulting from the separate loading directions are listed in Table 4.

**Table 4 – tensile components for special cases**

Stresses from	vertical transverse force $V_{Ed,\perp}$	"External" tensile force
Tensile force component	$Z_{Ed,V,\perp} = 0,25 \cdot V_{Ed,\perp}$	$Z_{Ed,N}$

Resulting total tensile force:

$$Z_{Ed} = Z_{Ed,V,\perp} + Z_{Ed,N}$$

- $Z_{Ed}$  [kN/m] : total tensile force per meter of joint
- $Z_{Ed,N}$  [kN/m] : "external" tensile force acting per meter of joint
- $Z_{Ed,V,\perp}$  [kN/m] : expansion force from vertical transverse force per meter of joint

## Bending of the anchoring loop

In the case of elements with small dimensions, the anchoring loop in all rail systems can be bent. The bending dimensions shown in Figures 12 to 14 are appropriate examples of this. In the case of an angle joint, a stirrup with a  $\varnothing$  8 mm is arranged in the area of the bent loop (Figs. 13).

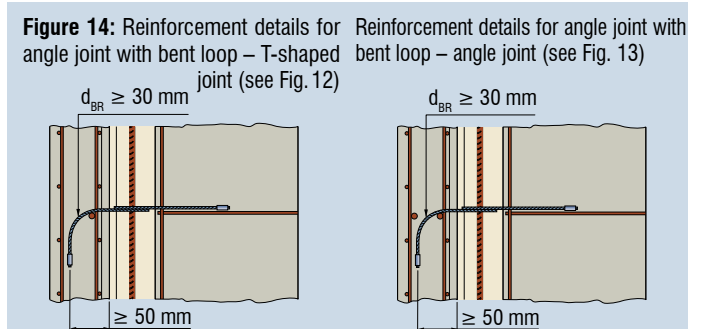
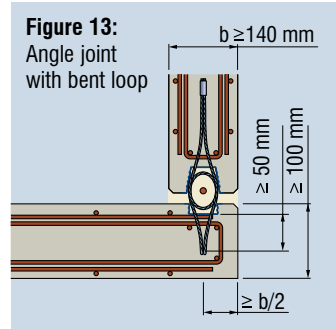
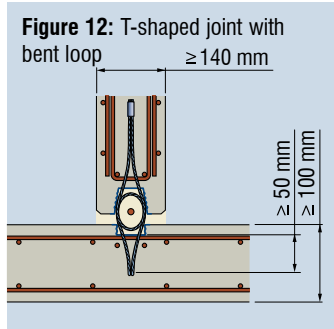

## Reinforcement

Reinforcing must be installed in the reinforced concrete precast parts as shown in Figures 8, 9 and 15 for the VS® ISI/BZ System<sup>3D</sup>. If corresponding reinforcing is already foreseen for other static reasons, this can be taken into account.

### Stirrup reinforcement loops

One stirrup with  $\varnothing$  8 mm all 236 mm must be provided per rope loop and anchored in the component (Figs. 8, 9 and 15). This forms an overlap with the rope loop anchoring. The anchoring lengths of the stirrup and also the necessary concrete covers of the stirrup must be fixed by the responsible designer acc. to the chosen concrete quality.



As an alternative to the stirrups, it is also possible to mount an equivalent mesh cap Q257 A.

### Surface reinforcement

Surface reinforcement or further reinforcement are not regulated in the technical approval and must be fixed by the responsible structural designer according to the static conditions.

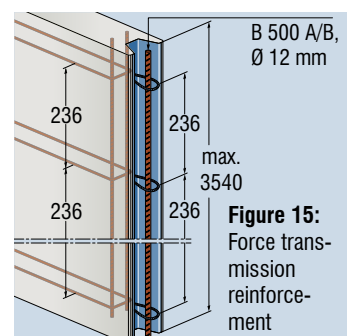

**Figure 15:** Force transmission reinforcement

## Constructive reinforcement

It is recommended to guide the surface reinforcement into the side flanks to the right and left of the rail profiles in order to protect it constructively from damage. In addition, continuous angle irons ( $\varnothing$  10 mm) are also recommended.

## Joint reinforcement

Before filling the joint, steel reinforcement bars diameter 12 mm must be inserted in the vicinity of the loop overlapping (Figs. 8, 9 and 15) over the entire height of the joint. It is statically imperative to have this reinforcement bar because it serves as gap pull reinforcement in the joint.

## Component joints

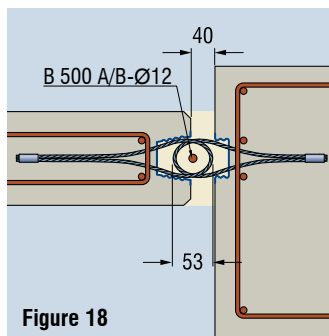
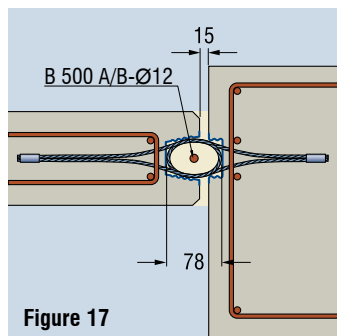
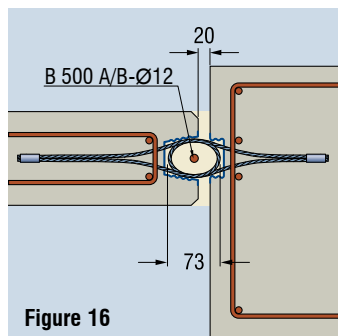

Control joint = 20 mm (Fig. 16)  
 Minimum joint = 15 mm (Fig. 17)  
 Maximum joint = 40 mm (Fig. 18)  
 Here, the loop overlaps vary between 53 mm and 78 mm.

## Tolerances

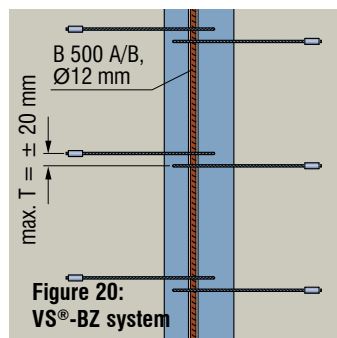
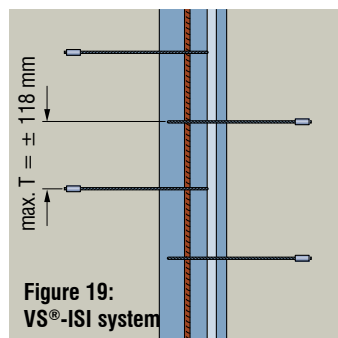

In the normal case the joint must be planned in the vertical direction without offsetting the loops (fig. 19). If the joints extend over a number of floors, it may in some circumstances be useful to set regular zero points for orientation of the rail sections.



Maximum vertical tolerance (fig. 20):  
 VS®-ISI system:  $\max T = \pm 118$  mm  
 VS®-BZ system:  $\max T = \pm 20$  mm

## Information on fire prevention

If demands regarding the fire resistance duration are placed on the VS® ISI system or the construction as a whole, the regulations according to DIN EN 1992-1-2:2010-12 in conjunction with DIN EN 1992-1-2/NA:2010-12 apply. DIN EN 1992-1-2:2010-12 applies in conjunction with DIN EN 1992-1-2/NA:2010-12 and DIN 4102-4:1994-03 to the execution as a fire wall. The steel reinforced precast concrete element connections using the VS® ISI System<sup>3D</sup> can be regarded as equivalent to the connections governed by DIN 4102-4:1994-03, sections 4.8.5 to 4.8.8.

For the verification of supporting connections exposed to fire, the working load limits according to Table 6 may be applied. According to the temperature acting on the wire rope loop, the design resistances are to be reduced with  $\alpha_{fi}$  (see temperature profile DIN EN 1992-1-2:2010-12, figure A.2). Loads vertical to the joint cannot be verified in the event of a fire.

**Table 5:** Design resistance values

	Tensile force $Z_{Rd,fi}$ [kN/wire rope loop]	Shear force parallel to the joint $V_{Rd,fi,II}$ [kN/m]
Dimensioning value of the working load limit	$Z_{Rd,fi} = \alpha_{fi} \cdot Z_{Rd}^{1)}$	$V_{Rd,fi,II} = \alpha_{fi} \cdot V_{Rd,II}^{2)}$

<sup>1)</sup>  $Z_{Rd}$  according to ISI/BZ approval Appendix 9, Table 1

<sup>2)</sup>  $V_{Rd,II}$  according to ISI/BZ approval Appendix 9, Table 2



**Notice:**

The approval texts for the VS® ISI and VS® BZ Systems<sup>3D</sup> must always be used as an integral part of these installation instructions. In case of doubt the approval is always authoritative.

**Figure 21:** Reduction factor  $\alpha_{fi}$  depending on rope temperature

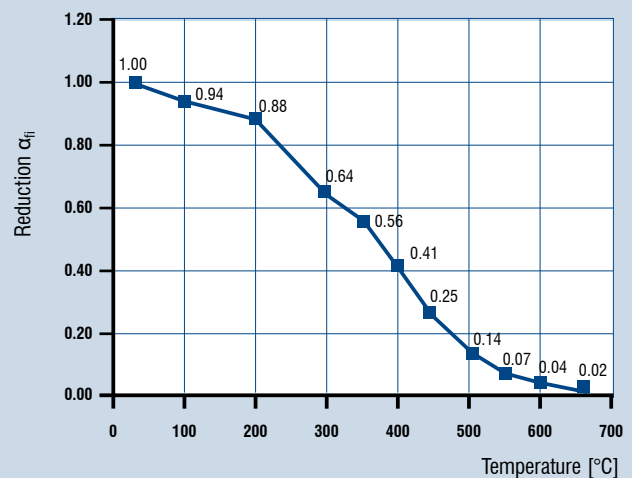

## Manufacture of the steel reinforced concrete precast elements

In the case of a precast part connection with the VS® rail system, the grouting groove is automatically created by the rail profiles. This means that no additional recess bodies, no additional depths or similar elements must be provided here. When mounting the VS® rails and long boxes into the formwork, the rope ends must be threaded into the reinforcement as straight as possible. After that, the profiles are nailed in a simple way beginning at the lower point of construction unit for both construction units or are glued with hot adhesive to the steel formwork (Fig. 24). Fixing the loops on the mesh reinforcement prevents the rail and the loops from slipping. The rope end anchorings must be arranged at less than 90° to the joint. The profiles must be arranged with the arrows upwards. They must be positioned so that overlaying loops correspond exactly in height.

### After removing the formwork

After stripping out the formwork, the flexible covering film is simply removed by pulling it off (Fig. 25). After that, the inside of the VS® profile is free and the rope loops are visible. The rope loop can easily be tilted out (Fig. 26). The loop must stick out vertically from the construction unit and, after tilting out, must spring back into this position when mounting the construction units. This is important for guaranteeing a perfect overlap. The wall construction units are now ready for final mounting on the construction site.

### Mounting the precast parts

The joints, the rail profiles and the loops must be free from soiling or separating humidification.

The wall units are either set in the permissible connection type (page 16) or on a mortar bed or onto leveling plates. The construction units must be levelled in such a way that the position and the height correspond with each other. A spacing between the joints of between 15 mm to 40 mm is possible in accordance with the technical approval. Vertically the loops should overlap touching opposite each other whilst complying with the specified maximum tolerances.

**Warning:** Because the different length of the loops the VS® ISI System and the VS® BZ 50 System are **NOT compatible to each other.**

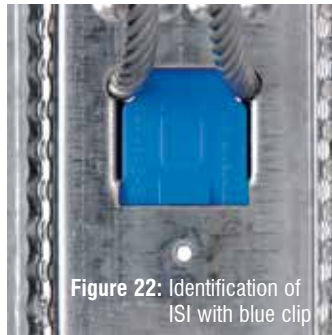

Figure 22: Identification of ISI with blue clip

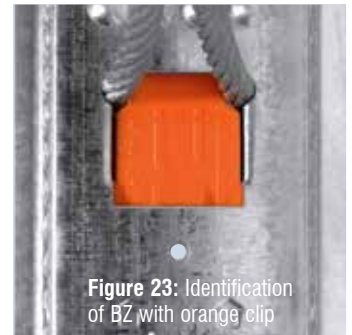

Figure 23: Identification of BZ with orange clip

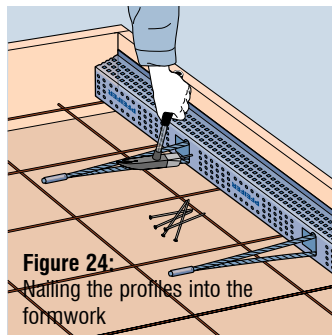

Figure 24: Nailing the profiles into the formwork

**!** PFEIFER application support should be contacted for installation variants that differ from Figure 24 where **increased formwork compression** is expected. This is the case with upright or battery formwork, for example!

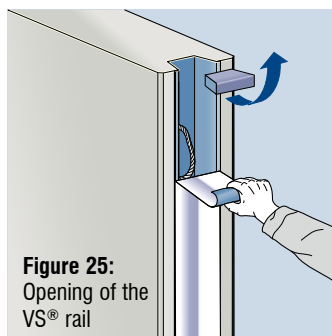

Figure 25: Opening of the VS® rail

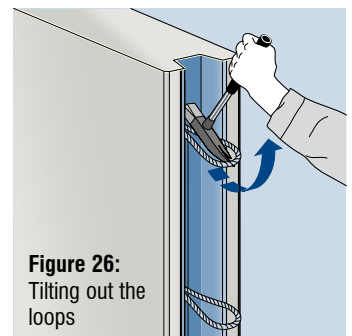

Figure 26: Tilting out the loops

### Software for dimensioning

The approved PFEIFER-VS® rail systems can be easily planned on precast wall joints with the aid of the free dimensioning software. The latest version of the software is available to download from the Internet at [www.pfeifer.info](http://www.pfeifer.info). Your additional benefits when using the software are:

- Permanently storable processor data and one-off project data
- Automatic quantity calculation for a complete project – mortar (litres and dry quantity) and VS® product
- Automatic verification of the connection Generation of a complete mathematical verification Calculations for the widest range of applications:
  - Wall-wall joint
  - Wall-column joint
  - Wall-corner
  - Wall panel complete
  - with constant and changing loads
  - with shear force parallel and vertical
  - with tensile forces
- Integrated fire protection verification



# Permitted VS<sup>®</sup> rails and joint material combinations

		VS <sup>®</sup> -ISI System <sup>3D</sup>	VS <sup>®</sup> -BZ System <sup>3D</sup>
<b>PAGEL<sup>®</sup></b> <b>Spezialbeton GmbH &amp; Co. KG</b> Wolfbankring 9 D-45355 Essen Telephone +49 (0) 201 685 040 Fax +49 (0) 201 685 0431 Email info@PAGEL.com Internet www.PAGEL.com	VS <sup>®</sup> -PAGEL <sup>®</sup> grout	✓	✓
	VS <sup>®</sup> -P PAGEL <sup>®</sup> joint filling mortar	✗	✓
<b>P &amp; T</b> <b>Technische Mörtel GmbH &amp; Co. KG</b> Bataverstrasse 84 41462 Neuss Telephone +49 (0) 2131 5669-0 Fax +49 (0) 2131 5669-22 Email info@eurogrout.de Internet www.eurogrout.de	EuroGrout <sup>®</sup> Varix	✓	✗
	EuroGrout <sup>®</sup> universal filler	✓	✗
<b>BETEC<sup>®</sup></b> <b>GCP Germany GmbH</b> Alte Bottroper Str. 64 45356 Essen Telephone +49 (0) 201 86147-0 Fax +49 (0) 201 86147-43 Email info.betec@gcpat.com Internet www.gcpat.de	Betec <sup>®</sup> VS <sup>®</sup> grout	✓	✗
	Betec <sup>®</sup> VS <sup>®</sup> thixotropic	✓	✗



**Notice:**

The manufacturer's information must be observed for processing! You will also find detailed information there regarding processing, and an extensive list of recommended devices. Technical details can also be found in the technical documentation issued by the respective company.

## Grout



- Highly penetrating
- Simple handling
- High design resistance
- No feed pump required
- Even relatively few joints can be filled economically

This high strength and extremely free flowing grout flows perfectly into the recesses of the PFEIFER VS<sup>®</sup> systems. As a result there are no strength-limiting faults. In combination with the PFEIFER-VS<sup>®</sup> FDS Joint Pressure Formwork, this mortar makes it possible to fabricate extremely high-quality joint casting quickly and securely. The material can also be used with VS<sup>®</sup> rail systems<sup>3D</sup>.

## Joint filling mortar



- Plastic and stable in the joint without formwork
- Less preparatory work is required
- Mixing and conveying can be done in one step
- Pump conveying to the joint

The PFEIFER VS<sup>®</sup> ISI System<sup>3D</sup> has an optimised profile without unfavourable recesses. It is therefore possible to use a mortar that is plastic/thixotropic and that stands in the joint independently. The big advantage of this is that only very little formwork is needed here. This technology offers significant savings, particularly on large building sites with many metres of joint.

## VS® rail system joints with grouting material

### Information and tips

The properties of the grout in the joint play an important role in a load-bearing connection of precast concrete elements with the PFEIFER-VS® system elements. The specially developed grouting materials have proven their suitability in combination with the PFEIFER VS® rails system in elaborate tests. These grouts are approved within the framework of the building authority approvals.

### Grout characteristics

- ✓ Highly free flowing
- ✓ Shrinkage-compensated
- ✓ Resistant to frost and de-icing salt
- ✓ Can be pumped with mixing and feed pumps
- ✓ Corrosion-resistant
- ✓ Production certified to DIN ISO 9001
- ✓ Supplied as a bagged product (bags of 25 kg)

### Mixing

The material is delivered as a ready-to-mix product and only needs to be mixed with water according to the instructions printed on the packaging. The material is then immediately ready to use.

### Casting the joint

The grout is poured in continuously until the desired level (max. 3.54 m) is reached. The formwork must be able to absorb the stress that arises from this.

Compacting is not necessary. Degassing by poking with the reinforced concrete steel bar or the fitting of a vibrator is, however, recommended. The grout bonds very quickly and allows rapid continuation of work. After the corresponding bonding times, the joint can be loaded to the permitted scope.

### Consumption

The PFEIFER Suite dimensioning software works out the grout volume for the selected grouting joint with the real quantities and masses of the project entered, displays the number of sacks for this.

The table below makes it possible to calculate an estimate of the fully-filled joints; an average grout consumption per metre of joint, based on walls that are 3.5 m high, is given.

**Table 6 – casting volume in case of standard joint (2 cm)**

	Wall thickness [cm]					
	14	16	18	20	22	24
VS® ISI System <sup>3D</sup>	6.68	7.08	7.48	7.88	8.28	8.68
VS® BZ System <sup>3D</sup>	8.50	8.90	9.30	9.70	10.10	10.50

Amount in l/m for standard joint 2 cm;  
approx. 2 kg of material are required per l

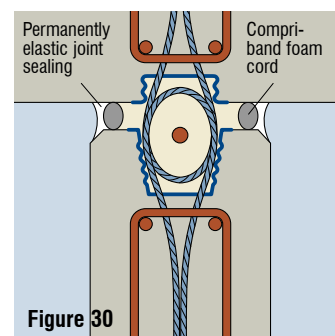
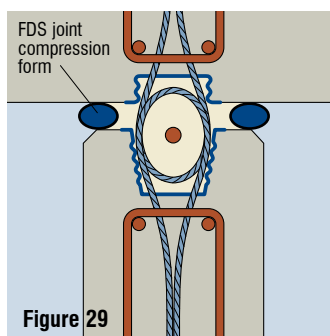
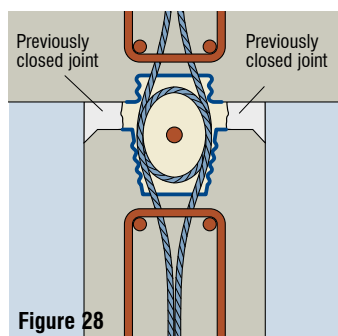
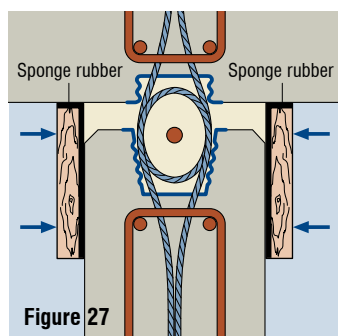

### Joint formwork variants

#### 1. Board formwork (Figure 27)

In order to completely fill joints between precast elements, a shuttering board is to be attached on both sides. It is recommended that foam rubber is applied to the shuttering boards in order to compensate for unevenness. If the shuttering boards are correctly fixed and it is assured that the grout material cannot escape, the joint can be filled as described in the section entitled "Filling the joint". After the material has hardened the formwork can be removed, cleaned and reused.

#### 2. Mortar seal (Figure 28)

Another variant makes it possible to close the joint flanks with a mortar. After this mortar has hardened, the core of the joint can be filled with grouting material and the higher performance of the systems can be achieved.

#### 3. VS® FDS air tube form (Figure 29)

The air tube form consists of two 4 m-long air tubes. These are very slightly pumped and pressed into the joint slot, so that the casting space of the loops is not adversely affected. After the air tube is applied over the entire joint height, the air tubes are brought to the nominal pressure and the joint is sealed. Now the joint can be cast from above across the entire height of 3.54 m. After the grout has hardened, the air pressure can be released and the air tube removed. After cleaning, it can be used again. Please also observe the detailed installation instructions on page 20.

#### 4. Sealed comriband (Figure 30)

Another way to cast the joints with a grout is the variant sketched in Figure 30.

In this case, prior to casting, a foam cord/comriband is inserted into the joint in a defined manner, after which a permanently elastic jointing is applied.

After the joint sealing has completely hardened on both sides, the grout can be used without additional formwork measures. However, the stresses that occur during casting must be taken into account here.

These should be determined by the construction company and the appropriate casting sections selected so that any squeezing out of the joint sealing is prevented.



**Caution:** When the air tube form or precompressed tapes are pressed into the lateral joints without adversely affecting the casting space, the effective lateral concrete cover for the rails and for the rope loop is reduced. The residual cross-section must be at least 14 cm.

## VS® rail system joint with plastic/thixotropic joint filling mortar

### Information and notes

The advantage of the joint filling mortar is the filling of joints between precast elements, where formwork can mostly be dispensed with. The optimised, plastic/thixotropic properties of this mortar means that it is stable after being poured in the joint, without the need for further measures. The approval for the VS® System 3D covers tensile and transversal shear forces acting both in parallel and vertically in relation to the joint.

### Mortar characteristics

- ✓ Non-shrinking with gel-type consistency
- ✓ Ease of production
- ✓ Can be pumped with commercially available screw pumps
- ✓ High initial and final hardening strengths
- ✓ Frost and de-icing salt resistant
- ✓ Impermeable to water
- ✓ Low water/cement ratio
- ✓ Production certified to DIN ISO 9001
- ✓ Externally and internally monitored
- ✓ Supplied as a bagged product (bags of 25 kg)

### Mixing

The ready-to-use mortar supplied only needs to be mixed to a usable material by adding water. It is imperative to follow the mixing instructions on the bags.

### Joint filling

First completely close off one joint flank using foam cord, profiled rubber (Figure 31) or alternatively using JOINT FILLING MORTAR (Figure 32). After closing with joint filling mortar, wait for the mortar to become stiff. After this, working from the other side, the remaining joint, which is now closed on one side, should be filled from the bottom to the top evenly and continuously. Gently poking the joint with the filling nozzle or the filling pipe ensures a proper result. The joint can easily be drawn flat after having been filled.

### Joint formwork variants

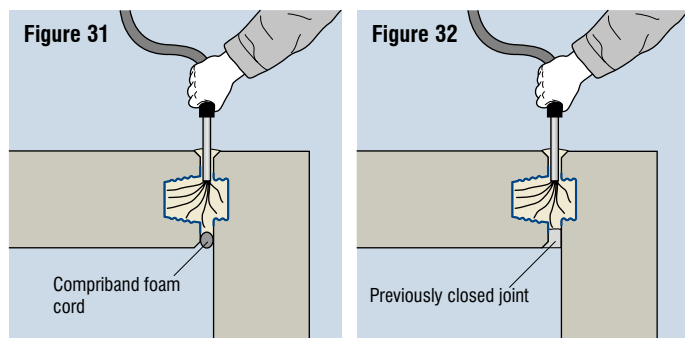

### Nozzle manufacture

The filling nozzle, made of commercially available 22 mm (3/4") copper heating pipe (with the aid of a solder fitting for connecting to the pump air tube), can be attached (Figs 33 and 34).

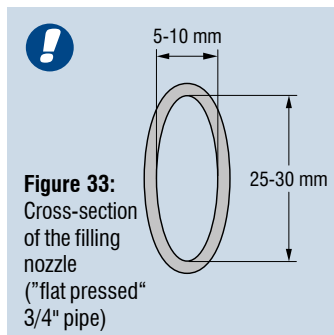

**Notice:** This information only applies to placing the material in the joint!

**Caution: do not constrict filling space:** If pre-compressed strips are to be pressed into the side joints without affecting the grouting space, the effective lateral concrete coverage of the rail and the rope loop is reduced. This must also be taken into account by the planners in the dimensioning.

### Qualification

Suitable machinery and instructed personnel are important for the quality and efficiency of the mortar system.

If necessary, enquiries regarding instruction can be made at any time to the mortar manufacturers.

### Storage

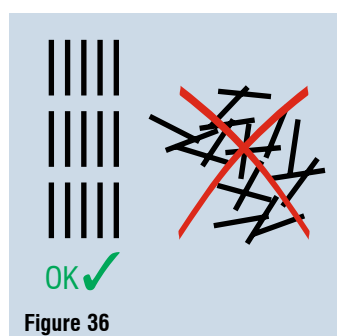
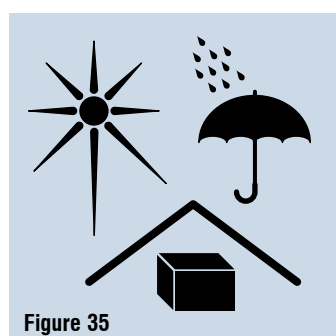

# PFEIFER



The contact details of our locations and sales partners can be found at



[www.pfeifer.info/contacts-cls](http://www.pfeifer.info/contacts-cls)

We look forward to hearing from you!

**PFEIFER  
SEIL- UND HEBETECHNIK  
GMBH**

DR.-KARL-LENZ-STRASSE 66  
D-87700 MEMMINGEN

PHONE Technical  
Support +49 83 31-937-345  
Sales +49 83 31-937-231

FAX +49 83 31-937-342

E-MAIL [export-bt@pfeifer.de](mailto:export-bt@pfeifer.de)

INTERNET [www.pfeifer.info](http://www.pfeifer.info)

This document is superseded when  
a new edition appears at [www.pfeifer.info](http://www.pfeifer.info).